

HEAT TRANSFER ENHANCEMENT BY USING TWISTED TAPE INSERTS WITH CIRCULAR HOLES IN FORCED CONVECTION

Prof. Kurhade Anant Sidhappa

Department of Mechanical Engg. APCOER, SPPU, India,

Miss. Sonal S. Hande

Department of Mechanical Engg. APCOER, SPPU, India,

Mr. Swarup B. Patil

Department of Mechanical Engg. APCOER, SPPU, India,

Mr. Vivekanand R. Maske

Department of Mechanical Engg. APCOER, SPPU, India,

ABSTRACT

In the present work heat transfer and friction factor properties were experimentally investigated by using copper wavy twisted tape inserts with circular holes in forced convection. The turbulent flow was created by inserting the wavy twisted tape inserts into the test pipe creating high rate of turbulence in pipe, which results in increasing heat transfer enhancement and pressure drop. The tape consists of the circular holes and the twisting with various twist ratios (TR=5.5, 6.5, 8.5). The length and width of insert was 500 mm and 16 mm respectively. The outside diameter & inside diameter of test pipe is 32 mm & 28 mm respectively. The length of test section is 500 mm. The bulk mean temperatures at various positions are used for different flow rate of air. From the obtained results the new Correlations for Nusselt number and friction factor are developed for twisted tape inserts. The Reynolds number is varied from 2000 to 12000. The results of varying twists in wavy twisted tape inserts with different pitches have been compared with the values for the smooth tube. It showed that the highest heat transfer rate was achieved for the wavy twisted tape with twist ratio 5.5.

KEYWORDS - Heat transfer, wavy twisted tape with circular holes, turbulent, pressure drop, friction factor, Reynolds number, Nussult number.

INTRODUCTION

In heat exchanger, the enthalpy is transferred between two or more fluids, at different temperatures. The use of heat exchangers are in various industrial processes for heating and cooling applications such as air conditioning and refrigeration systems, heat recovery processes, food and dairy processes, chemical process plants etc. The major challenge in designing a heat exchanger is to make the equipment more compact and achieve a high heat transfer rate using minimum pumping power. Techniques for heat transfer augmentation are relevant to several engineering applications. In recent years, the high cost of energy and

material has resulted in an increased effort aimed at producing more efficient heat exchange equipment. Sometimes there is a need for miniaturization of a heat exchanger in specific applications, such as space application, through an augmentation of heat transfer. These problems are more common for heat exchangers used in marine applications and in chemical industries. The heat transfer rate can be improved by introducing a disturbance in the fluid flow thereby breaking the viscous and thermal boundary layer. However, in the process pumping power may increase significantly and ultimately the pumping cost becomes high. Therefore, to achieve a desired heat transfer rate in an existing heat exchanger at an economic pumping power, several techniques have been proposed in recent years and are discussed under the classification section. The heat transfer enhancement techniques are performed in widespread applications. The results of those studies have been shown that although heat transfer efficiencies are improved, the flow frictions are also considerably increased. In this report the various wavy twisted tapes are used for heat transfer enhancement having various twist ratios. The strips are expected to induce a rapid mixing and a high turbulent and longitudinal vortex flow like a delta wing, of course, resulting in an excellent rate of heat transfer in the tube.

EXPERIMENTAL SET-UP

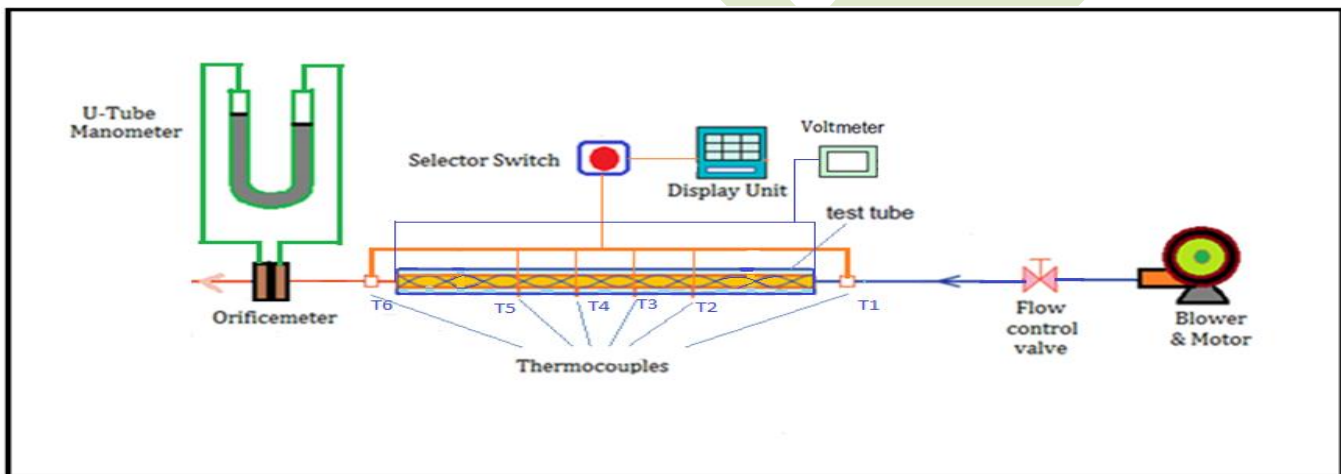

Fig. 1 The schematic diagram of experimentation

The experimental set up and the various measuring devices are shown in fig. 1 & fig. 2. The apparatus consist of a blower unit fitted with the test pipe. The test section is surrounded by nichrome heater. Four thermocouples are embedded on test section and two thermocouples are placed in the air stream at the entrance and exit of test section to measure air temperatures. Test pipe is connected to the delivery side of the blower along with the orifice to measure flow of air through the pipe. Input to the heater is given through power unit and is measured by meters. It is also noted that only a part of the total heat supplied is utilized in heating the air. A temperature indicator is provided to measure the temperature in the pipe wall in the test section. Air flow is measured with the help of an orifice meter and the water manometer fitted on the board. The valve at the outlet of pipe is used to vary the flow rate of air. At inlet of test section a tapping with valve is provided to measure pressure drop.



Fig. 2 Actual photograph of experimentation

PROCEDURE

Start and adjust the flow by means of a valve to some desired difference in the manometer level. Start the heating of test section with the help of dimmer stat and adjust the desired heat input by means of voltmeter and ammeter. Take the readings of all the thermocouples at an interval of 10 min. until the steady state is reached. Wait for the steady state and take readings of six thermocouple at steady state. Repeat the procedure for with twisted tape insert having twist ratio 5.5, 6.5, 8.5. Calculate the heat transfer rate with the help of readings taken for with & without inserts.



Fig. 3 Twisted tape with TR – 5.5

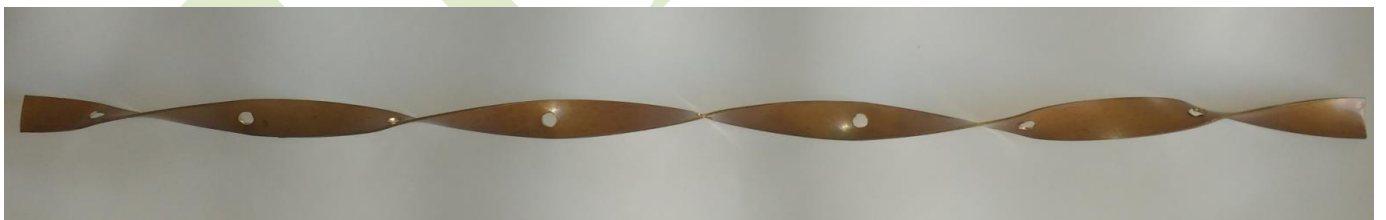

Fig. 4 Twisted tape with TR – 6.5



Fig. 5 Twisted tape with TR – 8.5

SPECIFICATIONS OF INSERTS

- Width of tape, $W = 16$ mm (Constant)
- Thickness of inserts, $t = 1.2$ mm (Constant)
- Length of insert, $L = 500$ mm (Constant)
- Hole diameter, $d=6$ mm (Constant)
- Pitch, $P = 85,105,135$ mm
- Twist ratios, $TR = 5.5,6.5,8.5$ mm

SAMPLE CALCULATIONS

The Properties of hot water and cold water are calculated at their bulk mean temperature,

1. Avg. Surface Temp., $T_s = (T_2 + T_3 + T_4 + T_5) / 4$
2. Avg. Temperature of air, $T_b = (T_1 + T_6) / 2$

From average temperature of air, we calculate the properties of dry air at atmospheric pressure,

3. Air volume flow rate,

$$Q_a = cd \times A_o \times \sqrt{\frac{2 \times g \times H \times \rho_w}{\rho_a}}$$

4. Mass flow rate,

$$\dot{m}_a = q_a \times \rho_a$$

5. Velocity of air,

$$V = \frac{q_a}{A}$$

6. Reynolds number of fluid,

$$Re = \frac{v \times Di}{\nu}$$

7. Theoretical friction factor,

$$f_{th} = (1.82 \times \log_{10} Re - 1.64)^{-2}$$

This equation is used to find friction factor called as Petukhov equation for smooth surface.

8. Theoretical Nusselt number,

$$Nu_{th} = 0.023 \times Re^{0.8} \times Pr^{0.4}$$

This equation is called Dittus-Boettier equation.

9. Experimental friction factor,

$$f_{exp} = \frac{\Delta P}{\frac{L}{Di} \times \frac{\rho_a v^2}{2}}$$

Here, Pressure drop,

$$\Delta P = h \times \frac{\rho_w}{\rho_a}$$

10. Experimental Nussult number,

$$Nu_{exp} = \frac{hDi}{k}$$

Here, Heat transfer coefficient of pipe,

$$h = \frac{q}{A_{pipe}(T_s - T_b)}$$

Air heating rate,

$$q = mc_p \Delta T$$

RESULT AND DISCUSSION

After the experimental study, the Nusselt numbers and friction factors were calculated for plain tube and tube with twisted tape inserts. These results were compared with the correlation of Dittus and Boelter for Nusselt number & Petukhov equation for friction factor. Figure 1 shows the graph of Nusselt number Vs Reynolds number for plain tube. It is found that there is linear behavior of Nusselt number along Reynolds number. Nusselt number is a function of Reynolds number. Figure 2 shows the graph of friction factor Vs Reynolds number for plain tube. The friction factor is inversely proportional with Reynolds number.

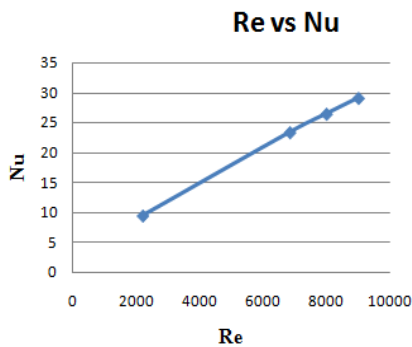

Fig.6 Reynolds number Vs Nusselt number

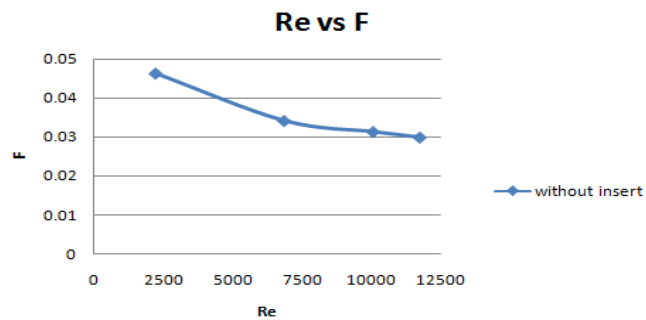

Fig.7 Reynolds number Vs Friction factor

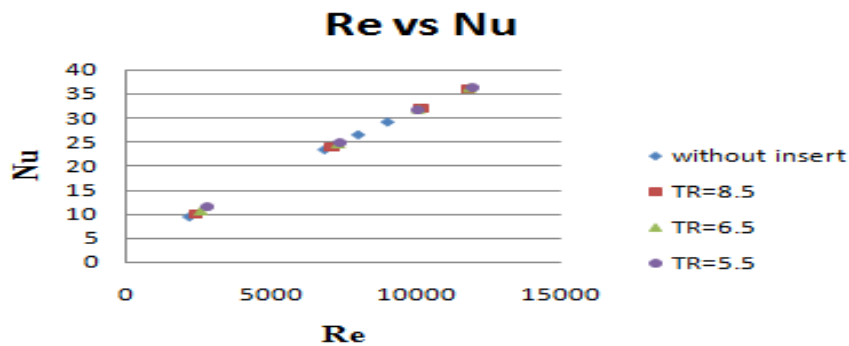

Fig.8 Reynolds number Vs Nusselt number for TR=8.5, 6.5, 5.5

Figure 3 shows the variation of Nusselt number with Reynolds number at various twist ratios (TR=8.5, 6.5, 5.5). This figure concludes that the Nusselt number increases with increase in Reynolds number. Therefore heat transfer rate is more with higher Reynolds number. Here Nusselt number is more for the twisted tape with lesser twist ratio (TR=5.5) for particular Reynolds number compared with other twisted tapes. So highest heat transfer rate was obtained for lesser twist ratio.

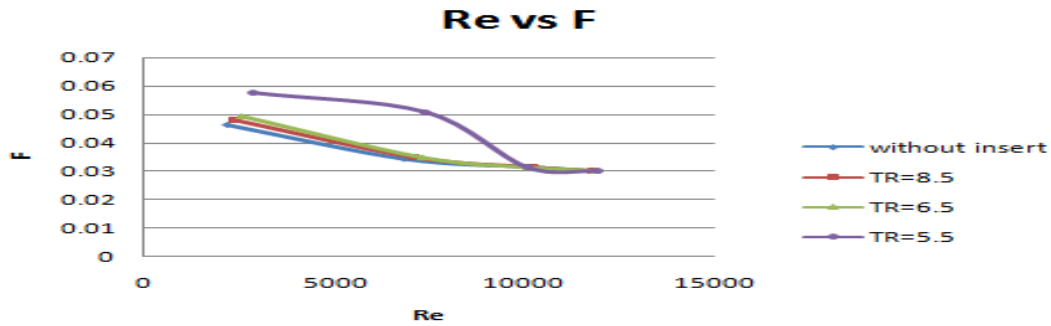

Fig.9 Friction Factor Vs Reynolds number for TR=8.5, 6.5, 5.5

Figure 4 shows the variation of friction factor with Reynolds number. It was found that the friction factor become greater as the twist ratio decreased. The value of friction factor is more for the wavy twisted tape insert having twist ratio 5.5 as compared with other inserts. The friction factors for the case of the insert having twist ratio 5.5, 6.5 & 8.5 were 0.435, 0.285 and 0.154 times over the plain tube respectively.

CONCLUSIONS

By using twisted tape inserts the highest heat transfer rate was achieved for twist ratio 5.5. In comparison with plain tube all twisted tape inserts would significantly enhance the heat transfer rate. The more twist increased the heat transfer and decreased the friction factor. From this experimental study the results can be concluded as follows,

For Reynolds number range 2000 to 12000, the Nusselt number for twisted tape insert with twist ratio 8.5, 6.5 and 5.5 was found to be 23.99%, 25.64% and 29.32% respectively.

The Friction factor is increased approximately by 0.20%, 0.2673 % and 0.4545 % with twist ratio 8.5, 6.5 and 5.5 respectively.

Nomenclatures,

Ao	Area of orifice, m ²	Re	Reynolds number
Cp	Specific heat, J/Kg K	V	velocity of air, m/sec
f	Friction factor	L	Length of test pipe, mm
h	Heat transfer coefficient, W/m ² K	v	Kinematic viscosity of water ,m ² /sec
k	Thermal conductivity, W/mK	ρ	Density of water, kg/m ³
Nu	Nussult number	Pr	Prandlt number
ΔP	Pressure drop, m	q	Air heating rate, kcal/kg
H	Manometric head, mm of hg	Cd	Coefficient of discharge

REFERENCES

- [1] “*Heat Transfer Behavior In A Tube With Conical Wire Coil Inserts*”, Mr. Kumbhar D.G., Dr. Sane N.K.
- [2] “*Experimental Investigations In A Circular Tube To Enhance Turbulent Heat Transfer Using Mesh Inserts*”, Naga Sarada S., Kalyani K. Radha & A. V. S. Raju, 2009.
- [3] “*Heat Transfer & Friction Factor Of Coil-springs Inserted In The Horizontal Concentric Tubes*”, Haydar Eren, Nevin Celik.
- [4] “*Experimental Investigation of Heat Transfer Performance of Wavy Twisted Tape Inserts Using MATLAB*”, Sneha S.Pedram1, Dr. K.P.Kolhe, and U.S.Gawai . April 2015
- [5] “*Fuzzy Logic Modeling of Heat Transfer in an Air Cooler Equipped with Butterfly Insert*”, A. Karami, E. Rezaei, M. Shahhosseni, and S. Feiz Jafari, August 2011.
- [6] “*Effect of Twisted-tape Inserts on Heat Transfer in a Tube*” Watcharin Noothong, Smith Eiamsa-ard and Pongjet Promvonge, (SEE 2006) (P) 21-23 November 2006, Bangkok, Thailand.
- [7] “*Enhancement of heat transfer in a horizontal circular tube using mesh inserts in turbulent region*”, Shruthi C.P. 2008 B.Tech Thesis, JNTU Hyderabad.
- [8] “*Thermal Augmentation in Circular Tube With Twisted Tape and Wire Coil Turbulators*,” Promvonge, P., 2008, Energy Convers. Manage., 49, pp. 2949–2955.
- [9] “*The experimental investigation of heat transfer and pressure drop in a tube with coiled wire inserts placed separately from the tube wall*”, Sibel Gunes, VeyselOzceyhan , Orhan Buyukalaca, Applied ThermalEngineering30(2010).
- [10] “*CFD and experimental studies on heat transfer enhancement in an air cooler equipped with different tube inserts*,” S. R. Shabanian, M. Rahimi, M. Shahhosseni, A. A. Alsairafi, *Int. commun. Heat. Mass. Transf.*, vol. 38, pp. 383–390, 2011.