

TESTING & ANALYSIS OF TORQUE LIMITER TIMER BELT SPINDLE DRIVE FOR OVERLOAD PROTECTION

Pankaj Thakuji Thorve.

Department of Mechanical Engineering, Savitribai Phule Pune University / Sahyadri Valley College of
Engineering & Technology, Rajuri, Pune, India. * pankajthorve@gmail.com

Dr. S.B. Zope

Department of Mechanical Engineering, Savitribai Phule Pune University / Sahyadri Valley College of
Engineering & Technology, Rajuri, Pune, India. * s.b.zope99@gmail.com

ABSTRACT

Positive clutches are used to transmit power between two coincident shafts. The positive engagement between the clutch elements ensures 100% torque transmission. But occasionally the output shaft may be subjected to a sudden overload which may make the driving motor or engine to stall or overheat. It will lead to burnout of the electric motor. In extreme cases this overload will lead to the breakage of drive elements or the clutch itself. In order to avoid the damage of the transmission elements it is necessary that the input and output shafts be disconnected in case of sudden overloads. The isolation of the input driver member i.e. motor from the output member is absolutely necessary to avoid damage and it is possible by using ball clutch assembly.

Torque-Limiters are Overload Safety Devices with Torque Limiters which provide reliable overload protection. When a jam-up or excessive loading occurs the Torque Limiter will reliably and quickly release to prevent system damage.

INTRODUCTION

These torque limiters are tamper-proof. Once installed, the torque value cannot be changed. This is an important feature that ensures the integrity of the machine design. Costly and potentially risky calibration procedures are not necessary. The torque value is controlled by the part number that is ordered. That value determines what spring is used during the assembly at the factory. The torque value can be changed in the field, however; the torque limiter must be disassembled and the springs replaced to achieve the new torque value. Standard Torque-Limiters are bidirectional. The torque value is the same regardless of rotation. If specified, these torque limiters can be configured at the factory to release at different torque ratings for different rotational directions. In the coupling configuration, the Torque-Limiter fulfils two functions: (1) A flexible shaft coupling (2) a mechanical torque limiter. The Torque-Limiter in the shaft to shaft configuration will handle angular shaft misalignment up to 1.5 degrees and a .005" to .015" maximum parallel misalignment. The enclosed design of the mechanical torque limiter enables it to operate in a wide variety of industrial environments. Special designs and materials can be made to withstand even more adverse conditions. Zero-Max torque limiters are made from durable heat treated steel for a long operational life.

DISADVANTAGES OF CURRENT SYSTEM OF OVERLOAD PROTECTION

- Rating of clutch is 1N-m, 5 N-m, 20 N-m etc. i.e. fixed value so if o/p torque change we have to replace clutch.
- Every time ball comes out of assembly we have to remove the clutch to replace ball this increases down time of machine
- Drive always remains coupled there is no flexible arrangement like automobile clutch i.e. possibility to disengage at will.
- If temporary overload occurs the clutch will slip and remain disengaged till it is preset even though the overload is now removed this leads to process down time.
- Thus there is a need of Timer belt spindle drive with overload Safety ball clutch with following features

ADVANTAGES OF OVERLOAD TORQUE LIMITER

To protect the drive from failure, flying ball clutch is available in market. It transmits torque from input to output using balls held by a spring in assembly when overload occurs the balls will come out of assembly –thus disconnecting input and output thereby saving part failure.

- At the time of electromechanical disengagement drive can be temporarily disengaged for in process inspection or other activity
- The Safety ball clutch can be set over a range of torques (say 0 to 20 kg-cm) so that the machine operator can set it to desired value for given application unlike the conventional clutches which are factory set.
- The transmission elements i.e., the balls will not come out of assembly when there is overload slipping. This is the advantage as the clutch can be preset without removing it from assembly this will save considerable amount of downtime of process as compared to the conventional clutch.
- If temporary overload occurs the clutch will slip and remain disengaged only till the overload is removed thus if the overload is removed while in running condition the clutch shall automatically engage and start transmitting power.

LITERATURE REVIEW

[1] Dynamic simulation of the safety clutches with balls Nicolae EFTIMIE conclude that the most important parameters, which influence in a major manner the safety clutches working are: the ratio between the inertia moments at the driven and driving parts, the spring's type and consequently their rigidity and the pretension springs force

[2] Modeling and Validation of a back-torque limiter using the example of a BMW motorcycle power train Albert Albers Philipp Merkel, Martin Geier, I. Dreher, H. Städele found that The introduced back torque limiter is used in a specific BMW motorcycle power train and can avoid a blocked rear wheel during braking and simultaneous shift down.

[3] Elastic and safety clutches with intermediate rubber elements Stroe Ioan "Transilvania" University of Braşov Concluded that the elastic and safety clutches with metallic roles and elastic rubber elements present the following advantages:

1. The clutches ensure the limitation and the adjustment of the transmitted moment;
2. The clutch can take over technological and assembling deviations

[4] Design development, testing and analysis of torque limiter for overload protection. Samarth Sanjay Khairnar1, Dr.S.N.Shelke conclude that safety clutch is easily adjusted to transit a range of different torques

[5] Torque Tender /Limiter For Overload Shaft Kiran Kumar Chandrakant Labade found The enclosed design of the mechanical torque limiter enables it to operate in a wide variety of industrial environments. Special designs and materials can be made to withstand even more adverse conditions

[6] Spring Loaded Torque Limiter Mr. Kadam A. N1 Mr. Aitavade E. N2 conclude that

The spring loaded ball clutch (torque limiter) ensures the,

- (1) The limitation and the adjustment of the transmitted moment.
- (2) The torque limiters can take over technological and assembling deviations.

DESIGN AND ANALYSIS

- System design to find number of ball-springs required for desired torque capacity.
- Design and geometrical derivations of the groove profile in input base flange.
- Design and geometrical derivations of spring plunger profile.
- Selection and geometrical profile of clutch body ball holder.
- Selection and design of torque control using plunger and casing arrangement.
- Selection of solenoid coil for transmission of desired power
- Selection of timer belt drive for open belt drive
- Mechanical design : This includes the design and development of springs selection of suitable drive motor, strength analysis of various components under the given system of forces
- The critical components of assembly input pulley, solenoid mount, Safety ball clutch input shaft, input base flange, plunger, cylindrical body, output shaft etc., components will be designed using conventional theories of failure using various formulae, 3-D models of the above parts will be developed using

Unigraphics software and meshing –analysis will be done, the result of stress produced will be validated using ANSYS-Workbench 14.5 release.

EXPERIMENTAL SET UP AND ANALYSIS OF COMPONENT

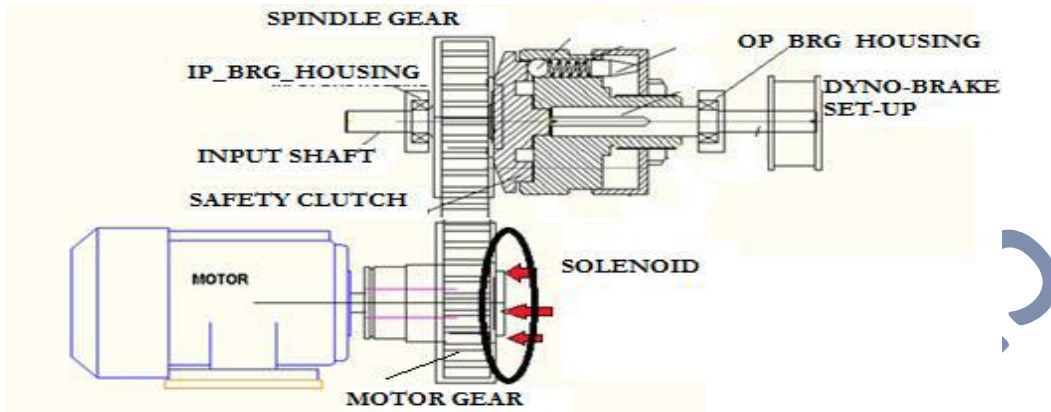

Fig1.Setup

ANALYSIS OF COMPONENTS

1. SHAFT

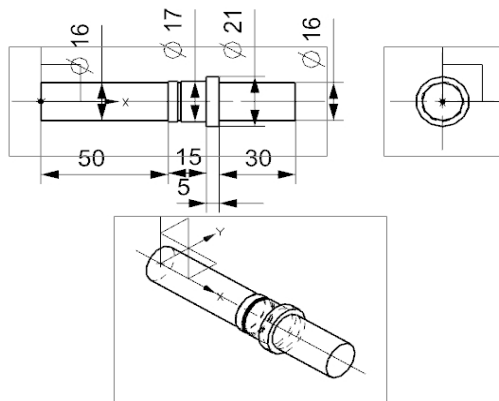

Fig.2 Design

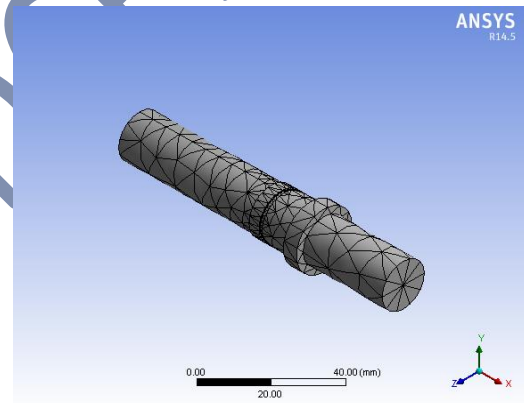

Fig. 3 Modelling and Meshing of shaft

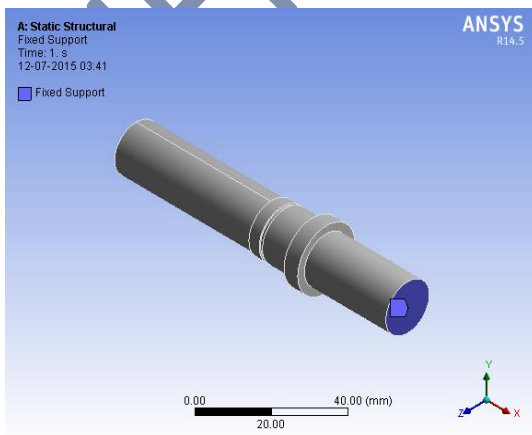

Fig.4 Boundry Conditions

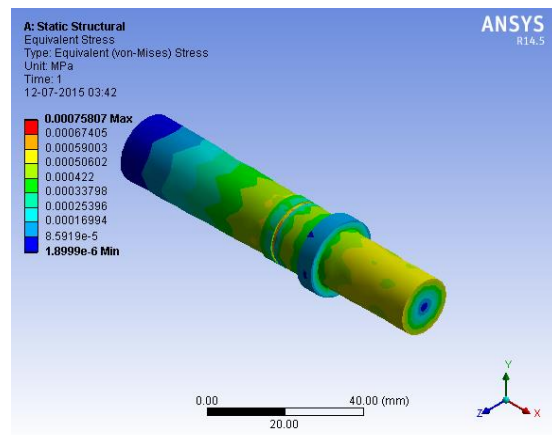

Fig.5 Result

2. PLUNGER

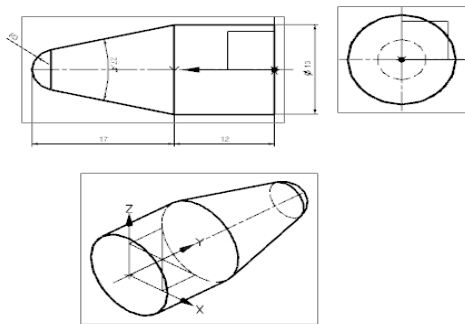

Fig 6. Design of plunger

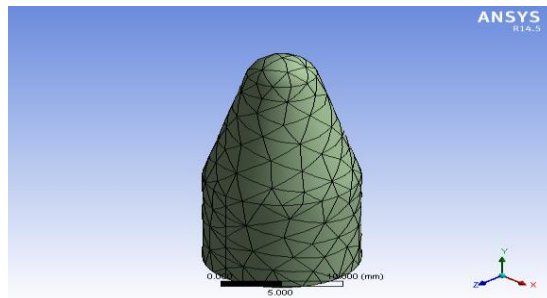

Fig 7. Modelling and Meshing of plunger

3.HUB ASSEMBLY

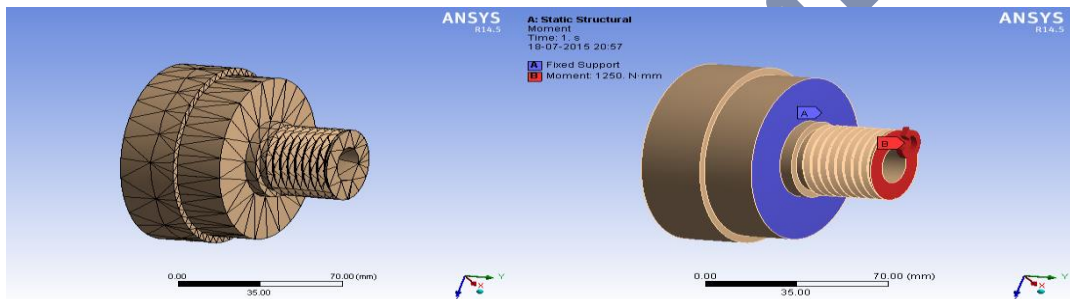

Fig.8 Modelling and Meshing of Hub

Fig. 9 Boundry Conditions

SAMPLE CALCULATIONS: - (AT 0.6 KG LOAD)

- 1) Average Speed :-

$$N = \frac{N_1 + N_2}{2} = \frac{850 + 850}{2} = 850 \text{rpm}$$
- 2) Output Torque:-

$$T_{dp} = \text{Weight in pan} \times \text{Radius of Dynobrake Pulley}$$

$$= (0.6 \times 9.81) \times 37.5$$

$$= 202.725 \text{ N.mm}$$

$$T_{dp} = 202.75 \text{ N.mm}$$
- 3) Input Power:- ($P_{i/p}$)

$$P_{i/p} = \frac{2 \Pi N T_{i/p}}{60}$$

$$= \frac{2 \times \Pi \times 850 \times 0.225}{60}$$

$$P_{i/p} = 20.27 \text{ watt}$$
- 4) OutPut Power:-($P_{o/p}$)

$$P_{o/p} = \frac{2 \Pi N T_{o/p}}{60}$$

$$= \frac{2 \times \Pi \times 850 \times 0.203}{60}$$

$$P_{o/p} = 18.06 \text{ watt}$$
- 5) Efficiency:-

$$\eta = \frac{\text{Out put power}}{\text{Input power}}$$

$$= \frac{18.06}{20.27} \times 100$$

$$\eta = 89 \%$$

⇒ Efficiency of transmission of Torque Tender = 89%

PHOTOGRAPHS OF FINISHED COMPONENT



Fig 10 Nut



Fig. 11 Casing



Fig. 12 Bearing Housing



Fig. 13 Base Flange

EXPERIMENTATION AND RESULT

After conducting experiment on test rig following result obtained.

Table1. Result table

Load	Speed	Torque	Power	Efficiency
50	990	0.012263	1.27145	23.11727
100	974	0.024525	2.501802	45.48731
150	965	0.036788	3.718027	67.60049
200	948	0.04905	4.870037	88.54613

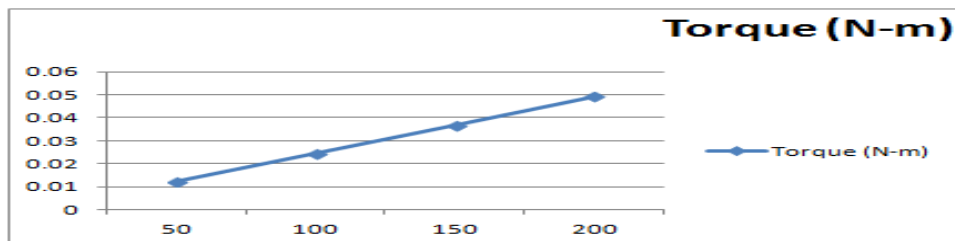

Fig. 14 Torque Vs Speed result for clutch

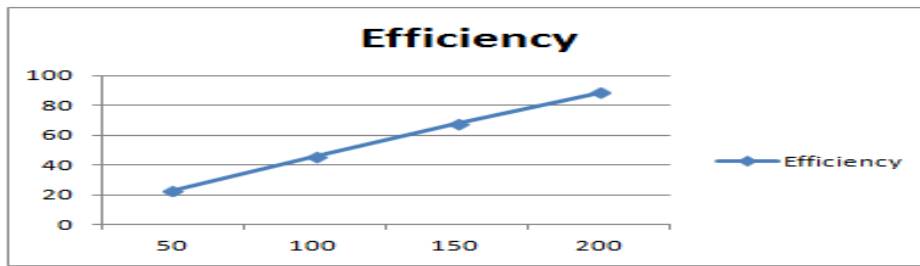

Fig. 15 Efficiency Vs Speed result for clutch

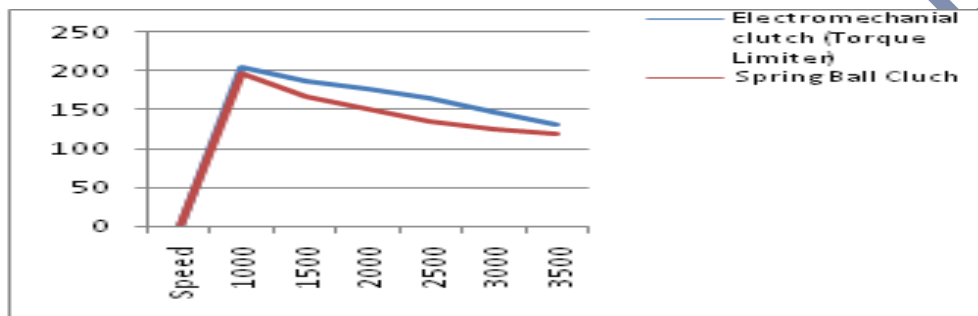

Fig. 16 Load Vs Speed result for clutch

CONCLUSION

- 1) From the result table, it is observed that; as load increases speed reduces.
- 2) Torque and efficiencies are inversely proportional to speed.
- 3) And most important, we can have disengagement at output shaft when there is overload also, can disengage at our will.
i.e., definitely we can avoid damage and burning of motor, resulting more safety.

REFERENCES

- [1] Geier M., Dreher I., Albert Albers Philipp Merkel, Modeling and Validation of a back-torque limiter using the example of a BMW motorcycle power train
- [2] Kadam A. N. and Aitavade E. N., Spring Loaded Torque Limiter, IJSRD - International Journal for Scientific Research & Development, Vol. 2, Issue 06, 2014.
- [3] Khainar S.S. and Shelke S.N., Design development, testing and analysis of torque limiter for overload protection.
- [4] Labade K.C., Torque Tender /Limiter For Overload Shaft, International Journal of Engineering Research & Technology (IJERT), Vol. 3 Issue 8, August – 2014
- [5] Nicolae EFTIMIE, Dynamic simulation of the safety clutches with balls, faculty of technical sciences, Novi sad, May 18th 2007
- [6] Stroeloen, Elastic and safety clutches with intermediate rubber elements, "Transilvania" University of Braşov