

IMPROVEMENT OF POWER-QUALITY BY USING A VOLTAGE-CONTROLLED DSTATCOM

Mr. Prashant B. Pawar

PG Scholar Department Electrical Engineering, MSS'S CET, Jalna

Prof. K.Venkata Rama Mohan

Assistant Prof. Department Electrical Engineering, MSS'S CET, Jalna

Prof. Santhosh Kompelli

Assistant Prof. Department Electrical Engineering, MSS'S CET, Jalna

ABSTRACT

This Project proposes a new algorithm to generate reference voltage for a distribution static compensator (DSTATCOM) operating in voltage-control mode. The proposed scheme exhibits several advantages compared to traditional voltage-controlled DSTATCOM where the reference voltage is arbitrarily taken as 1.0 p.u. The proposed scheme ensures that unity power factor (UPF) is achieved at the load terminal during nominal operation, which is not possible in the traditional method. Also, the compensator injects lower currents and, therefore, reduces losses in the feeder and voltage-source inverter. Further, a saving in the rating of DSTATCOM is achieved which increases its capacity to mitigate voltage sag. Nearly UPF is maintained, while regulating voltage at the load terminal, during load change. The state-space model of DSTATCOM is incorporated with the deadbeat predictive controller for fast load voltage regulation during voltage disturbances. The state-space model of DSTATCOM is incorporated with the deadbeat predictive controller for fast load voltage regulation during voltage disturbances. With these features, this scheme allows DSTATCOM to tackle power-quality issues by providing power factor correction, harmonic elimination, load balancing, and voltage regulation based on the load requirement. Simulation and experimental results are presented to demonstrate the efficacy of the proposed algorithm.

KEYWORDS: DSTATCOM, STATCOM, VSI, PCC voltage, PQ Problems.

INTRODUCTION

A distribution system suffers from current as well as voltage-related power-quality (PQ) problems, which include poor power factor, distorted source current, and voltage disturbances. A DSTATCOM, connected at the point of common coupling (PCC), has been utilized to mitigate both types of PQ problems. When operating in current control mode (CCM), it injects reactive and harmonic components of load currents to make source currents balanced, sinusoidal, and in phase with the PCC voltages. In voltage-control mode (VCM), the DSTATCOM regulates PCC voltage at a reference value to protect critical loads from voltage disturbances, such as sag, swell, and unbalances. However, the advantages of CCM and VCM cannot be achieved simultaneously with one active filter device, since two modes are independent of each other. In CCM operation, the DSTATCOM cannot compensate for voltage disturbances. Hence, CCM operation of DSTATCOM is not useful under voltage disturbances, which is a major disadvantage of this mode of operation. Traditionally, in VCM operation; the DSTATCOM regulates the PCC voltage at 1.0 p.u. However, a load works satisfactorily for a permissible voltage range. Hence, it is not necessary to regulate the PCC voltage at 1.0 p.u. While maintaining 1.0-p.u. voltage, DSTATCOM [1] compensates for the voltage drop in feeder. For this, the compensator has to supply additional reactive currents which increase the source currents. This increases losses in the voltage-source inverter (VSI) and feeder. Another important aspect is the rating of the VSI. Due to increased current injection, the VSI is de-rated in steady-state condition. Consequently, its capability to mitigate deep voltage sag decreases. Also, UPF cannot be achieved when the PCC voltage is 1 p.u. In the literature, so far, the operation of DSTATCOM is not reported where the advantages of both modes are achieved based on load requirements while overcoming their demerits. The operation of DSTATCOM [1] in VCM and proposes a control algorithm to obtain the reference load terminal voltage. This algorithm provides the combined advantages of CCM and VCM. The UPF operation at the PCC is achieved at nominal load, whereas fast voltage regulation is provided during voltage disturbances.

SYSTEM MODEL AND ASSUMPTIONS

A distribution system suffers from current as well as voltage-related power-quality (PQ) problems, which include poor power factor, distorted source current, and voltage disturbances. A DSTATCOM, connected at the point of common coupling (PCC), has been utilized to mitigate both types of PQ problems. When operating in current control mode (CCM), it injects reactive and harmonic components of load currents to make source currents balanced, sinusoidal, and in phase with the PCC voltages. In voltage-control mode (VCM), the DSTATCOM regulates PCC voltage at a reference value to protect critical loads from voltage disturbances, such as sag, swell, and unbalances. However, the advantages of CCM and VCM cannot be achieved simultaneously with one active filter device, since two modes are independent of each other. In CCM operation, the DSTATCOM cannot compensate for voltage disturbances. Hence, CCM operation of DSTATCOM is not useful under voltage disturbances, which is a major disadvantage of this mode of operation. Traditionally, in VCM operation; the DSTATCOM regulates the PCC voltage at 1.0 p.u. However, a load works satisfactorily for a permissible voltage range. Hence, it is not necessary to regulate the PCC voltage at 1.0 p.u. While maintaining 1.0-p.u. voltage, DSTATCOM [1] compensates for the voltage drop in feeder. For this, the compensator has to supply additional reactive currents which increase the source currents. This increases losses in the voltage-source inverter (VSI) and feeder. Another important aspect is the rating of the VSI. Due to increased current injection, the VSI is de-rated in steady-state condition. Consequently, its capability to mitigate deep voltage sag decreases. Also, UPF cannot be achieved when the PCC voltage is 1 p.u. In the literature, so far, the operation of DSTATCOM is not reported where the advantages of both modes are achieved based on load requirements while overcoming their demerits. The operation of DSTATCOM [1] in VCM and proposes a control algorithm to obtain the reference load terminal voltage. This algorithm provides the combined advantages of CCM and VCM. The UPF operation at the PCC is achieved at nominal load, whereas fast voltage regulation is provided during voltage disturbances.

POWER QUALITY PROBLEMS AND ENHANCEMENT OF POWER QUALITY USING DSTATCOM

Power quality is influenced among other factors by utility operations, customer load types and equipment designs. Distribution utilities and their customers, along with their engineering equipment manufacturers and vendors, generate, propagate and receive power quality problems. Electrical disturbances can develop from problems within the customer's facility, even though the supply voltage is constant. Achieving power quality demands a united effort between the utility and the customer.

The DSTATCOM [2] consists of a current-controlled VSI as shown in fig.1 which injects current at the PCC through the interface inductor. The operation of VSI is supported by a dc storage capacitor. The transient response of the DSTATCOM [2] is very significant while compensating ac and dc loads. In some of the electric power consumers, such as the telecommunications industry, power-electronics drive applications, etc., there is a constraint for ac as well as dc loads. The telecommunication industry uses several parallel-connected switch-mode rectifiers to support dc bus voltage. Such an arrangement draws nonlinear load currents from the utility. This causes reduced power factor, more losses and less efficiency. Obviously, there are Power Quality issues, such as unbalance, poor power factor, and harmonics produced by telecom equipment in power distribution networks. Therefore, the functionalities of the conventional DSTATCOM should be increased to mitigate the above mentioned PQ problems [3] and to supply the dc loads from its DC Link as well. A DSTATCOM [4] simulation model has been created in MATLAB/ Simulink [4], then analyse the dynamic and steady-state performance of DSTATCOM. A distribution static compensator is a voltage source converter based power electronic device. Usually, this device is supported by short term energy stored in a dc capacitor. The DSTATCOM filters load current such that it meets the specifications for utility connection. The DSTATCOM can fulfil the following points.

1. The result of poor load power factor such that the current drawn from the supply has a near unity power factor.
2. The result of harmonic contents in loads such that current drawn from the supply is sinusoidal.
3. The result of unbalanced loads such that the current drawn from the supply is balanced.
4. The dc offset in loads such that the current drawn from the supply has no offset.

One of the main features of DSTATCOM is the generation of the reference compensator currents. The compensator, when it tracks these reference currents, injects three-phase currents in the ac system to cancel out disturbances caused by the load. Therefore, the generation of reference currents from the measurements of local variables has fascinated wide attention. These methods carry an inherent assumption that the source is stiff (i.e., the voltage at the point of common coupling is tightly regulated and cannot be influenced by the currents injected by the shunt device). This however is not a valid assumption and the concert of the compensator will reduce considerably with high impedance ac supplies. The operation of VSI is supported by a dc storage capacitor with

appropriate dc the transient response of the voltage across it. The transient response of the DSTATCOM [5]- is very significant while compensating AC and DC loads.

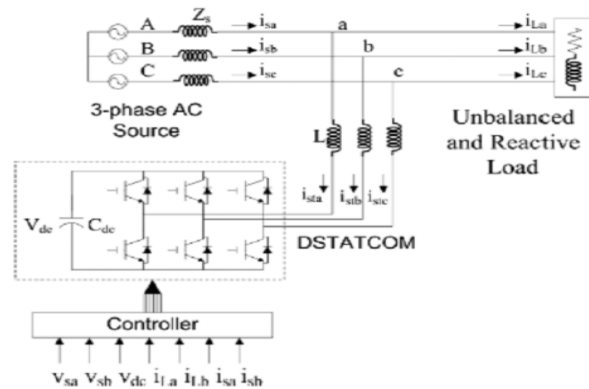

Fig. 1. Basic Circuit Diagram of the DSTATCOM System.

A static synchronous compensator (STATCOM) is one of the most operative solutions to regulate the line voltage. The STATCOM consists of a voltage source converter connected in shunt with the power system and permits to control a leading or lagging reactive power by means of correcting its ac voltage. A STATCOM for installation on a distribution power system called DSTATCOM [5]-, shown in fig.2 has been researched to clear voltage fluctuations and voltage flickers. A shunt active filter intended for installation on a power distribution system, with emphasis on voltage regulation capability. Theoretical investigation as well as computer simulation provides the dynamic performance of harmonic damping and voltage regulation. As a result, harmonic damping has the capability to improve the stability of voltage regulation. Thus, modification of the feedback gains makes it possible to decrease voltage fluctuation in transient states, when the active filter has the function of combined harmonic damping and voltage regulation. The simulation results are shown to verify the effectiveness of the active filter capable of both harmonic damping and voltage regulation.

PROPOSED CONTROL SCHEME OF DSTATCOM

Circuit diagram of a DSTATCOM [5]-compensated distribution system is shown in Fig. 2 It uses a three-phase, four-wire, two-level, neutral-point-clamped VSI. This structure allows independent control to each leg of the VSI. Fig. 3 shows the single-phase equivalent representation of Fig. 3 Variable is a switching function, and can be either or depending upon switching state. Filter inductance and resistance are and, respectively. Shunt capacitor eliminates high-switching frequency components.

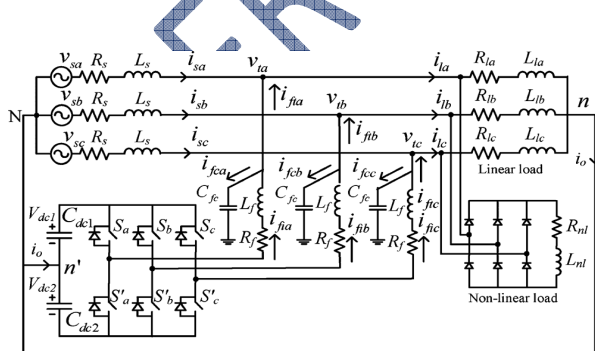

Fig. 2 Circuit diagram of the DSTATCOM-Distribution system.

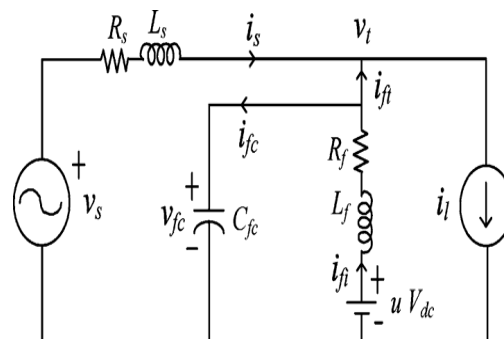

Fig.3 Single-phase equivalent circuit of compensated DSTATCOM.

First, discrete modelling of the system is presented to obtain a discrete voltage control law, and it is shown that the PCC voltage can be regulated to the desired value with properly chosen parameters of the VSI. Then, a procedure to design VSI parameters is presented. A proportional-integral (PI) controller is used to regulate the dc capacitor voltage at a reference value. Based on instantaneous symmetrical component theory and complex Fourier transform, a reference voltage magnitude generation scheme is proposed that provides the advantages of CCM at nominal load.

SIMULATION RESULTS

Initially, the traditional method is considered. Fig. 4 (a)–(c) shows the regulated terminal voltages and corresponding source currents in phases a, b and c, respectively. These waveforms are balanced and sinusoidal. However, source currents lead respective terminal voltages which show that the compensator supplies reactive current to the source to overcome feeder drop, in addition to supplying load reactive and harmonic currents..

Using the proposed method, terminal voltages and source currents in phases a, b and c are shown in Fig. 5 (a)–(c), respectively. It can be seen that the respective terminal voltages and source currents are in phase with each other, in addition to being balanced and sinusoidal. Therefore, UPF is achieved at the load terminal. For the considered system, waveforms of load reactive power (Q_{load}), compensator reactive power (Q_{VSI}), and reactive power at the PCC (Q_{PCC}) in the traditional and proposed methods are given in Fig.5 (a) and (b), respectively.

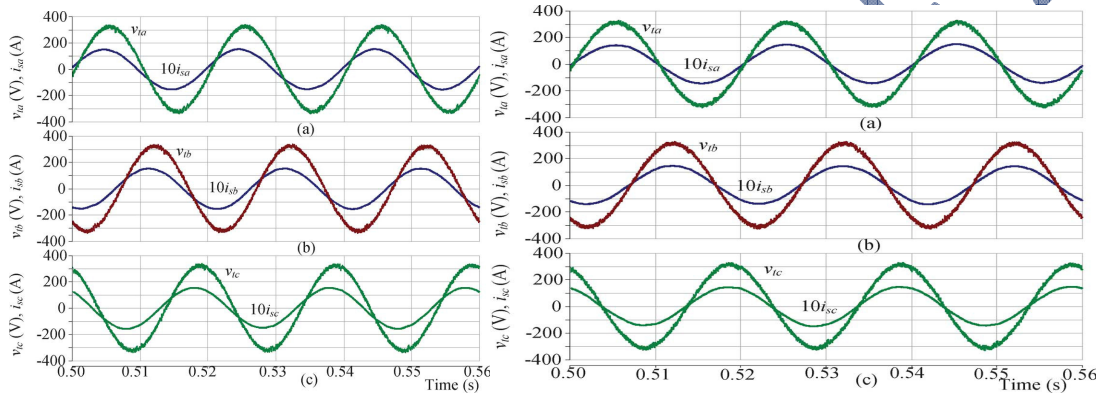

Fig. 4. Terminal voltages and source currents using the traditional method. Phase-a, Phase-b, Phase-c.

Fig. 5. Terminal voltages and source currents using the proposed method Phase-a, Phase-b, Phase-c.

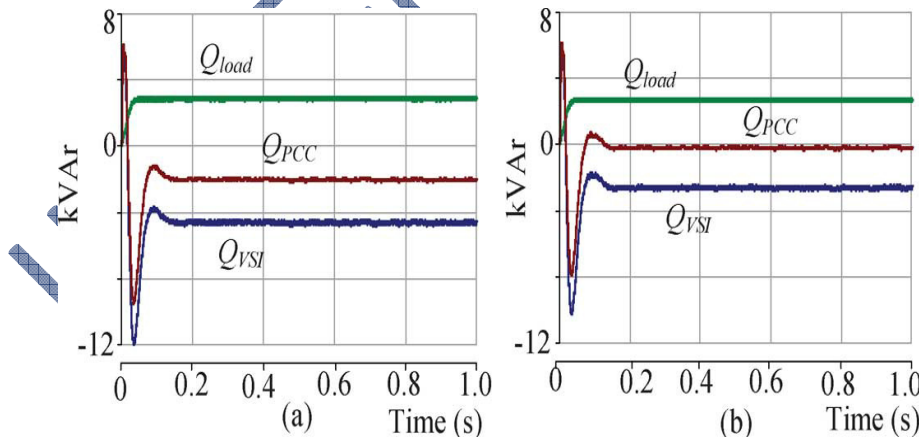

Fig. 6. Load reactive power (Q_{load}), compensator reactive power (Q_{VSI}), and reactive power at PCC (Q_{PCC}). (a) Traditional method (b) Proposed method

CONCLUSION

The performance of the proposed scheme is compared with the traditional voltage-controlled DSTATCOM. The proposed method provides the following advantages:

- 1) At nominal load, the compensator injects reactive and harmonic components of load currents, resulting in UPF;
- 2) Nearly UPF is maintained for a load change;
- 3) Fast voltage regulation has been achieved during voltage disturbances; and
- 4) Losses in the VSI and feeder are reduced considerably, and have higher sag supporting capability with the same VSI rating compared to the traditional scheme. The simulation and experimental results show that the proposed scheme provides DSTATCOM, a capability to improve several PQ problems (related to voltage and current).

REFERENCES

- [1] A. Ghosh and G. Ledwich, "Load compensating DSTATCOM in weak ac systems," IEEE Trans. Power Del., vol. 18, no. 4, pp. 1302–1309, Oct. 2003.
- [2] A. Elnady and M. Salama, "Unified approach for mitigating voltage sag and voltage flicker using the DSTATCOM," IEEE Trans. Power Del., vol. 20, no. 2, pt. 1, pp. 992–1000, Apr. 2005.
- [3] M. K. Mishra, A. Ghosh, A. Joshi, and H. M. Suryawanshi, "A novel method of load compensation under unbalanced and distorted volt-ages," IEEE Trans. Power Del., vol. 22, no. 1, pp. 288–295, Jan. 2007.
- [4] C N Bhende, Dr M K Mishra, Dr H M Suryawanshi, "A DSTATCOM Modelling, Analysis and Performance for Unbalanced and Non-linear Load" Vol. 86, March 2006, IE (I) Journal.
- [5] Bhim Singh, Senior Member, IEEE, P. Jayaprakash, Student Member, IEEE and D. P. Kothari, "A T-Connected Transformer and Three-leg VSC Based DSTATCOM for Power Quality Improvement", IEEE Transactions on power electronics, vol. 23, no. 6, November