

## Health Monitoring KIOSK: An effective system for rural health management

Rajalaxmi Das,  
*Sophitorium Institute of Technology & Life skills/Jatni/ Khurda/ Odisha/India*  
Himansu Mohan Padhy  
*Sophitorium Institute of Technology & Life skills/Jatni/ Khurda/ Odisha/India*

### **Abstract**

In the rural areas of our country, patients went to the public health centers (PHC) for their treatment. PHCs in India are allotted with hardly one doctor. It is really difficult at a single doctor's end to provide treatment to huge number of patients approaching a single doctor. Therefore, in this work it is proposed to develop an automated diagnosis system by developing a Health KIOSK.

The health KIOSK shall monitor and measure different physiological parameters of the body like heart rate, blood pressure, body- temperature, SpO<sub>2</sub>. The KIOSK comprises of signal conditioning & data acquisition systems. The parameters recorded by the KIOSK are stored in a database and can also be provided in printed output form. The patient can therefore approach the doctor with a printed data sheet about his/ her physiological parameters and also with a suggestive prescription for necessary consultation.

This approach shall save the time of the doctor and the treatment process can be implemented effectively.

**Key Words** — Blood Pressure Sensor, Health Monitoring Kiosk, Heart Beat sensor, Temperature Sensor, SPO<sub>2</sub> Sensor.

### **Introduction**

In rural areas of India the health management is a big problem. Here patients depend on the PHCs for their health issues. In PHCs there is only one doctor due to whom there is heavy rush in PHC's. The doctor measures body parameters by different bio sensing devices & take a note on pen & paper for future reference. Due to this trend the patient could not able to give proper service to each patient's due to lack of automated health monitoring system. Therefore in modern India to increase the patient care efficiency, there is a need of real time health monitoring system in every PHC.

The objective of health monitoring KIOSK is to have quantitative assessment of important physiological variables of patients during critical conditions. This system is used for measuring & recording the values of the patient's important physiological parameters such as blood pressure, body temperature, heart-beat, SPO<sub>2</sub>.

The output from all the sensors is in analog form. Then all data are digitized by a microcontroller and send to a PC by using USART serial communication. The data display on the PC with a designed format using Dot-net software. The designed format contains the patient's personal information, measured body parameter and a space for prescription.

This automated KIOSK saves time of a doctor for which doctor can give proper service to each patient in the rural areas.

## DESIGN & IMPLEMENTATION

In this process, design and implementation of “Health Monitoring Kiosk” is done with modules of data sensing, data processing and data communication as shown in Fig.1 The data sensing module contains three different bio sensor devices such as temperature sensor, heart rate & blood pressure sensor, Pulse Oximetry sensor. Each sensor output is interfaced with Analog to Digital converter (ADC) in a microcontroller. Here for data processing AtMega16 microcontroller (a 40-pin 8-Bit CMOS FLASH microcontroller/ a high-performance RISC CPU) is used. The processed data from the microcontroller is send to the PC by USART serial communication. MAX232 circuit is also used to solve problems in conversion of RS232 signal voltage to TTL voltage and needed to communicate the PC to display the current details of physiological parameters.

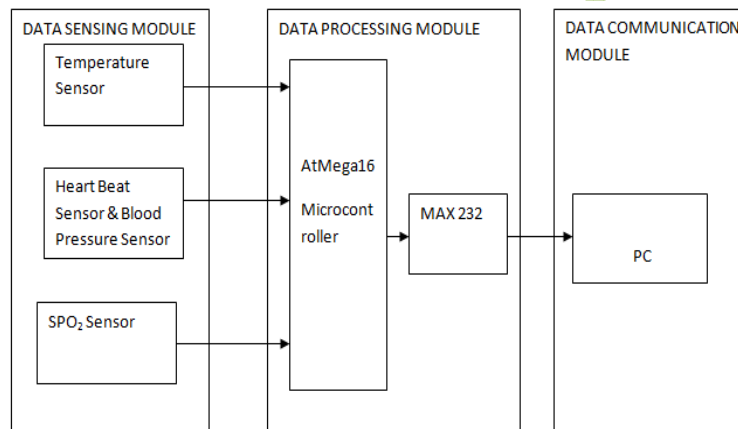

Fig.1 Blocks Diagram of Health Monitoring KIOSK

### DATA SENSING MODULE

#### TEMPERATURE SENSOR:

Various types of transducers are used to sense these bioelectrical signals. To sense the body temperature here AD595 with a K-type thermocouple is used. AD595 is a complete instrumentation amplifier and thermocouple cold junction compensator on a monolithic chip. It combines an ice point reference with a pre-calibrated amplifier to produce a high level ( $10 \text{ mV}/^\circ\text{C}$ ) output directly from a thermocouple signal.

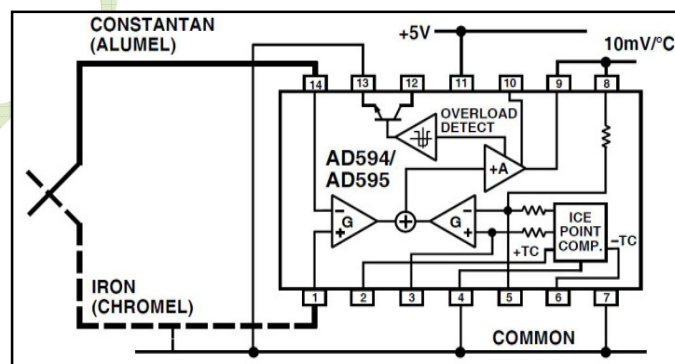

Fig.2 Circuit Diagram of AD595

## ***Heart Beat & Blood Pressure Sensor***

Here for measurement of both heart beat & blood pressure, a wrist-type device is used. It shows Systolic, Diastolic and Pulse Readings. Its compact design fits over the wrist like a watch. It shows the heart rate ranges in the form of beats per minute & the blood pressure is measured in millimetres of mercury ([mm Hg](#)) i.e 120/80 mm hg.

## ***SPO2 Sensor Probe for Pulse Oximetry:***

This sensor is useful in making Pulse Oximetry, which is a test that measures what proportion of the oxygen-carrying molecules in the blood (called hemoglobin) are actually carrying oxygen. This is known as oxygen saturation or SpO<sub>2</sub>. One hundred percent oxygen saturation is attained when all hemoglobin in the blood is completely saturated with oxygen. This simple test does not require a blood sample and is called non-invasive. Here a finger pulse oximeter is used. The sensor composed of IR and Red LEDs for sensing blood volume and blood oxygen saturation in the finger.

## ***Data Processing Module***

The data processing module contains AtMega16 microcontroller used for processing & controlling functions of the system and MAX 232 circuit used for conversion of signals to perform the communication. The ATmega16 is a low-power CMOS 8-bit microcontroller based on the AVR enhanced RISC architecture. It has 16 Kbytes of In-System Programmable Flash Program memory with Read-While-Write capabilities, 512 bytes EEPROM, 1 Kbyte SRAM for program storage. AtMega16 has inbuilt ADC (Analog to Digital Converter) for sampling and conditioning of signals. It is widely used in many applications for its various features such as more program storage & consumption of low power. MAX 232 circuit is a driver or receiver used to solve problems in conversion of RS 232 signal voltage to TTL voltage and to communicate data between hardware to PC.

## ***Data Communication Module***

For data communication between microcontroller and PC USART is used. It is a protocol for serial data communication. In USART data packet formation takes place which contain 8bit of data with a start bit & stop bit i.e single data packet contains 10bit. We are sending 15 character from microcontroller to PC where each & every character contain 8 data bit with a start bit & stop bit.

## ***Software***

For the communication between system and patient, a PC with a application is used to display the patient's information like patient's personal details, measured body parameters along with an suggestive prescription. This format is design by ASP.NET. ASP.NET is a development framework for building web pages and web sites with HTML, CSS, JavaScript and server scripting. Then all the patient information is stored in a database for future reference of doctor.

## ***Conclusion***

The system is mainly help the doctor in a PHC's for continuous monitoring and measuring of physiological parameters such as body temperature, heart- beat, blood pressure and SPO<sub>2</sub>. USART protocol is used for

data communication between micro-controller to PC. The main focus of this system is to save time of a doctor for giving proper service to all patients in rural areas.

### References:

1. Sharmili Minu.DH, Umamakeswari.A, "A Remote Health Monitoring Messenger", International Journal of Engineering & Technology, Vol.5, Issue 1, 2013.
2. Shriram K Vasudevan, Sivaraman R, Subashri V, "Design & Development of an Embedded System for Monitoring The Health Status of A Patient", I.J.Intelligent Systems & Application, Modern Education and Computer Science Press, 2013.
3. R.S.Khandpur, Handbook of Bio-Medical Instrumentation, 16th Edition, Tata McGraw Hill, Publishing Co. Ltd.2003.
4. AD595 User Module Data Sheet.
5. <http://www.oximetry.org/pulseox/principles.htm>
6. [http://www.howequipmentworks.com/physics/respi\\_measurements/oxygen/oximeter/pulse\\_oximeter.html](http://www.howequipmentworks.com/physics/respi_measurements/oxygen/oximeter/pulse_oximeter.html)
7. AtMega16 User Module Data Sheet
8. Manish m. Patil, Prof. Chaya S. Khandelwal, "Implementation of Patient Monitoring System Using GSM Technology", International Journal of Electronics And Communication Engineering & Technology, Vol.4, Issue 1, 2013.
9. Prema Sundaram, "Patient Monitoring System Using Android Technology", International Journal of Computer Science & Mobile Computing, Vol.2, 2013.
10. Surbhit Jain, Anshu Gupta, Praveen Kumar Malviya, "A Zigbee Based Wireless Patient's Monitoring System", The International Journal of Science & Technolodge, Vol. 2, Issue 4, 2014.
11. A.B. Tagad, P.N. Matte, " Design and Development of a Wireless Remote POC Patient Monitoring System Using Zigbee" International Journal of Emerging Technology and Advanced Engineering, Volume 3, Issue 12, December 2013.
12. D.J.R.Kiran Kumar, Nalini Kotnana, "Design and Implementation of Portable Health Monitoring system using PSoC Mixed Signal Array chip", International Journal of Recent Technology and Engineering (IJRTE), Volume-1, Issue-3, August 2012.

### Bibliographies:



**Rajalaxmi Das**, received her Bachelor's Degree from Biju Patanaik University of Technology in Applied Electronics & Instrumentation Engg in 2007 and Master's Degree in Applied Electronics & Instrumentation Engg from Siksha 'O' Anusandhan University of Technology in 2010. Currently she is working as the Asst. Professor in Sophitorium Group of Institutions, Bhubaneswar, Odisha. She is the Principal Investigator of the R & D Projects sponsored by DST, New Delhi.



**Dr. Himansu Mohan Padhy**, received his Bachelor's and Master's Degree from Berhampur University in 1991 and 1993 respectively. Awarded his Ph. D. degree in Electronics from Berhampur University in 2002. Currently he is working as the Professor in Sophitorium Group of Institutions, Bhubaneswar, Odisha. He is the Principal Investigator of Major Research Projects sponsored by DST, Govt of India, NRSC, Hyderabad and OSDMA, Govt of Odisha. He has published many papers in National and International journals.