

DESIGN AND ANALYSIS OF GEOMETRICAL PARAMETERS INFLUENCING ON CURVIC COUPLING

RAVIRAJ MADHEKAR

*Department Of mechanical engineering, V.V.P. Institute of engineering and technology, Solapur, India
raviraj.madhekar175@gmail.com*

PROF. BUDDHE M.V.

*Department Of mechanical engineering, V.V.P.Polytechnic, Solapur, India
maheshvilasbuddhe@gmail.com*

ABSTRACT

It has widely observed that bolts turn loose, when subjected to fluctuating loads. This ultimately reduces the force of bolt and leads to fail in the performance. Such failures can cause sudden great damage in safety critical applications. Therefore, it is necessary to design couplings with high positioning accuracy and high indexing stiffness. So the concept of curvic coupling was come in to existence. The stresses induced in the coupling have been analyzed by analytical method. A three dimensional finite element model of curvic coupling is developed in finite element software to compare to analytical results. The model consists of coupling assembly. A moment is applied on coupling & simulates the effects. Based on these results, a finite element analysis should be used if a greater level of detail is required for the analysis of curvic coupling.

KEYWORDS: indexing stiffness, curvic coupling ANSYS

INTRODUCTION

The curvic coupling was first developed by Gleason Works about sixty years ago. The curvic coupling is used for connecting shafts of gas-turbine engine. CURVIC is a trademark of The Gleason Works, 1000 University Avenue, Rochester, NY, 14603, USA. The curvic coupling is proved to be an important component in gas turbine, which are widely used in the aero-engine and electric power generation industry to drive rotating equipment and safely transfer high torque without relying on friction between the contacting surfaces of the curvic couplings.



Fig. Curvic Coupling, employed at both ends of this intermediate drive shaft.

The term "Curvic Couplings" refers to toothed connection members with the teeth spaced circumferentially about the face and with teeth which have a characteristic curved shape.

The three basic types of Curvic Couplings are (1) the fixed Curvic Coupling, (2) the Semi-Universal Coupling, and (3) Releasing Coupling (or clutch), The coupling is having high load carrying capacity.

PROBLEM DEFINITION:

Determination of shear stress and surface stress induced in curvic coupling:

Torque acting (T): 40000 N-mm

Curvic coupling Type: fixed curvic coupling

Material: Steel

Modulus Of elasticity(E): 2.1×10^5 MPa

Poisson's ratio (γ): 0.30

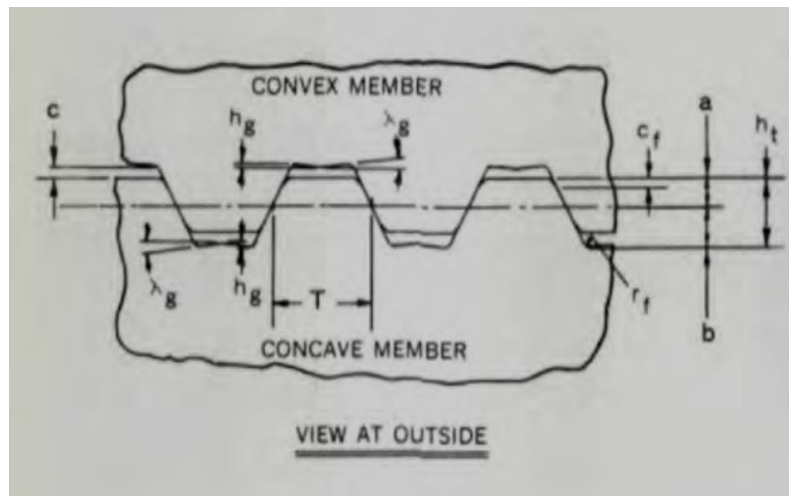

Fig : Fixed Curvic Coupling.

Given [5]:

Curvic coupling diameter (D) = 635 mm

Face width (F) = 49mm

No of teeth (N) : 08

Solution:

$$Pd = N/D$$

$$= 8/635$$

$$= 0.012 \text{ mm}$$

$$ht = 0.8/Pd$$

$$= 66.66 \text{ mm}$$

$$c = 0.1/0.012$$

$$= 8.33 \text{ mm}$$

$$ct = 0.090/0.012$$

$$= 7.5 \text{ mm}$$

$$H0 = 66.66 - 8.33 - 2 * 7.5$$

$$= 43.33 \text{ mm}$$

$$\text{Shear stress } S_s = \frac{T}{\pi A^2 F}$$

Shear stress $S_s = 302.83 \text{ N/m}^2$

$$\text{Surface stress } S_c = \frac{T}{AFNH0}$$

Surface stress $S_c = 803.74 \text{ N/m}^2$

ANALYSIS OF CURVIC COUPLING BY USING ANSYS

ANSYS is finite element analysis software which enables engineers to perform the following tasks:

- The solid model of curvic coupling is created in CATIA V5. It is solid modeling (SMO) software. There are many CAD softwares which give model tree for completed part, so that modification at any point can be done in the whole model.

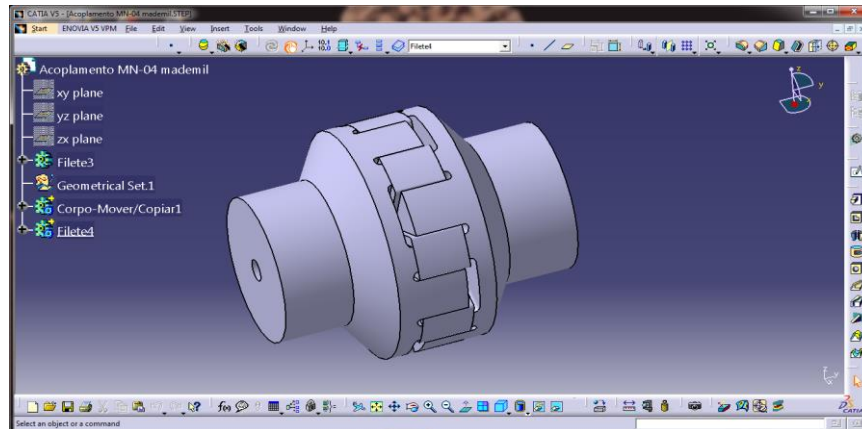

Fig: CAD model of curvic coupling

- The CAD model of curvic coupling was saved in STEP format for importing it into ANSYS workbench for the structural analysis purpose.
- The materials used for the curvic coupling are structural steel and silicon carbide which are in isotropic behavior.
- Mesh generation is a practice of generating a polygonal mesh that approximates a geometric domain
- Three-dimensional meshes created for finite element analysis need to consist of tetrahedral, pyramids, prisms or hexahedra.

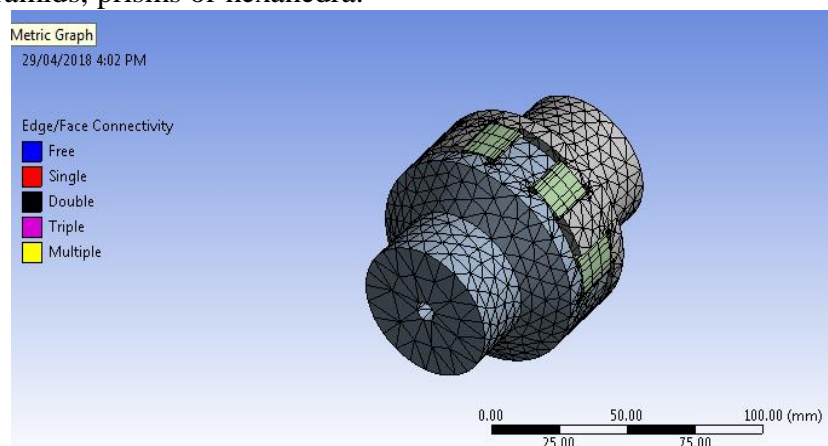
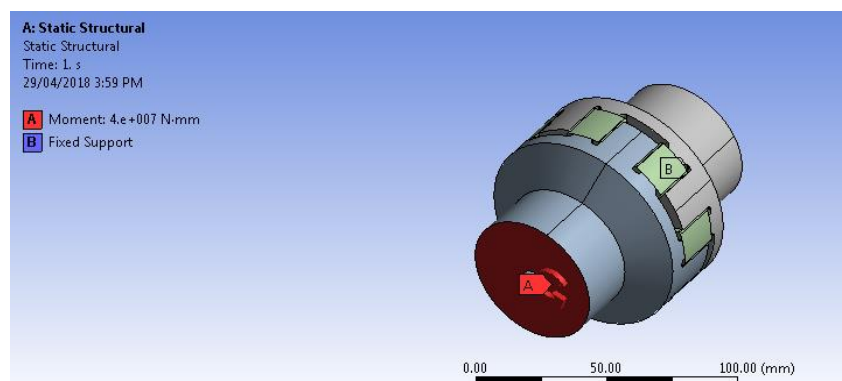

Fig: Meshed Geometry

- The boundary condition is the collection of different forces, moments, supports, and every condition required for complete analysis. Applying boundary condition is one of the most typical processes of analysis.



- In structural analysis, after specification of meshing, material properties, boundary conditions and application of loads, solution is obtained in terms of surface stress and Maximum shear stress.

RESULTS AND DISCUSSION

In this way, the analysis of curvic coupling is done by analytical and finite element method for finding the Surface stresses and maximum shear stress. The results are shown in table 5.1.

Table : Comparison between Analytical and Finite element Method

Types of Stresses (For moment 40000 N-mm)	Analytical Method	Finite element method	% of difference between Analytical and Finite element method
Surface Stress	803.74 Pa	869.1 Pa	8.11 %
Maximum Shear stress	302.83 Pa	314.51Pa	3.86 %

- Comparisons of results obtained from different materials used:

Table : Comparisons of stresses obtained from steel and SiC material

Types of Stresses (For moment 40000 N-mm)	Steel	Silicon Carbide
Surface Stress	869.19 Pa	648.65 Pa
Maximum Shear stress	314.51Pa	262.09 Pa

By comparing the results obtained from steel and silicon carbide material , it is concluded that surface stress and maximum shear stress induced in coupling as silicon carbide material are less as compared to steel material.

CONCLUSION AND FUTURE SCOPE:

CONCLUSION:

In this chapter, the main conclusions are drawn from the results obtained in the research.

- In this research, curvic coupling was considered as nonlinear model and surface stress and maximum shear stress were calculated for different materials.
- A comparative study has been made between steel and silicon carbide material for coupling
- From the results and discussion, it is concluded that surface stress and shear stress developed in silicon carbide material are less than alloy steel which shows suitability of silicon carbide for curvic coupling on the basis of strength.
- Also, coupling as Silicon carbide material is having less failure chances as compared to steel material due to less stresses developed.
- Hence, from the results obtained we can say that Silicon carbide coupling is having more life than steel coupling

FUTURE SCOPE:

- The work could be done by fatigue and vibration analysis of curvic coupling.
- The work could be done by analyzing the other remaining types of curvic coupling like semi-universal and releasing curvic coupling.

REFERENCES

- I. S.R. Pisani, J.J. Rencis, "Investigating CURVIC coupling behavior by utilizing two- and three dimensional boundary and finite element methods", Elsevier, Engineering Analysis with Boundary Elements 24, 2000, pp. 271–275.
- II. Jiang, X., Zhu, Y., Hong, J., Chen, X., Zhang, Y., Investigation into the loosening mechanism of bolt in curvic coupling subjected to transverse loading, Elsevier, Engineering Failure Analysis, 2013.
- III. Ying-Chien Tsai and Wei-Yi Hsu, "A Study on the CAD/CAM of Curvic Couplings", ASME Turbo Expo 2002: Power for Land, Sea, and Air, ISBN: 0-7918-3608-8 | eISBN: 0-7918-3601-0, pp. 1157-1162.
- IV. J. W. Choi, C. S. Kim, "A Study on the Stability of Curvic Coupling for Distance to Disk in a Mill Turret", Applied Mechanics and Materials, Vols. 110-116, Oct. 2011, pp. 1498-1505,
- V. J. Scalzo, R. L. Bannister, M. DeCorso and G. S. Howard, "Evolution of Westinghouse Heavy-Duty Power Generation and Industrial Combustion Turbines", J. Eng. Gas Turbines Power 118(2), 316-330 Apr 01, 1996.
- VI. Bradley James Nielson, "Thesis presented to the Faculty of California Polytechnic State University, San Luis Obispo", 2012.
- VII. Sathish Kumar N, "Investigation on the self-loosening behavior of hexagonal nut and nylock nut in curvic coupling under transverse loading", International Conference on Recent Trends in Engineering and Management, e-ISSN: 2278-1684, PP 63-66.