

Paper ID: NITETMECH02

## AN INNOVATIVE DESIGN & DEVELOPMENT OF MAGNETIC RECIPROCATING ENGINE

Jotiba L. Dune

Department of Mechanical Engineering  
Brahmdevdada Mane Institute of Technology, Belati, Solapur.  
jotibadune@yahoo.com

Vishal V. Nandarge

Department of Mechanical Engineering  
Brahmdevdada Mane Institute of Technology, Belati, Solapur.  
vishalnandarge1234@gmail.com

Ashwini M. Bhosale

Department of Mechanical Engineering  
Brahmdevdada Mane Institute of Technology, Belati, Solapur.  
ashubhosale777@gmail.com

Shankar S. Dhage

Department of Mechanical Engineering  
Brahmdevdada Mane Institute of Technology, Belati, Solapur.  
shankardhage91@gmail.com

Proff A.K.Athani.

Department of Mechanical Engineering  
Brahmdevdada Mane Institute of Technology, Belati, Solapur.

### ABSTRACT

Green Earth is the today's requirement. Which includes the control to pollution, green and effective power utilizing machineries, by considering the same we are going to design an engine which works on the magnetic force developed by the permanent and electromagnets? This paper gives the working and basic principles used to design the magnetic reciprocating engine.

**KEYWORDS:** magnetic engine, electromagnet, magnetic material, properties of magnets.

### INTRODUCTION

Today we are facing major problems of fuel crisis & pollution. The consumption of fuel is increased due to more usage of vehicles and at the same time availability of fuel is less. So lot of research is going on alternate fuels & maximum utilization of available. Magnetic reciprocating engine is the engine which runs on magnetic force developed by the permanent and electromagnet. This magnetic engine will run on electricity so there will be no fuel required to drive the engine. Due to this reason there will be great control to pollution.

### PROBLEMS REGARDING TO IC ENGINE:

1. Efficiency: efficiency of the IC engine is very less near about 25-35% only.
2. Pollution is also big problem.
3. Fuel crisis.
4. Unwanted noise etc

To overcome these problems we are developing the magnetic engine which works on following principles [1]

## PRINCIPLE OF WORKING OF MAGNETIC ENGINE:

This engine work on two basic principles,

### 1. PRINCIPAL OF MAGNET

Like poles repels each other and unlike poles attracts each other.

This will be the basic principle to achieve the reciprocations, where the magnet is successively attracted and repelled for achieving reciprocating action. [2]

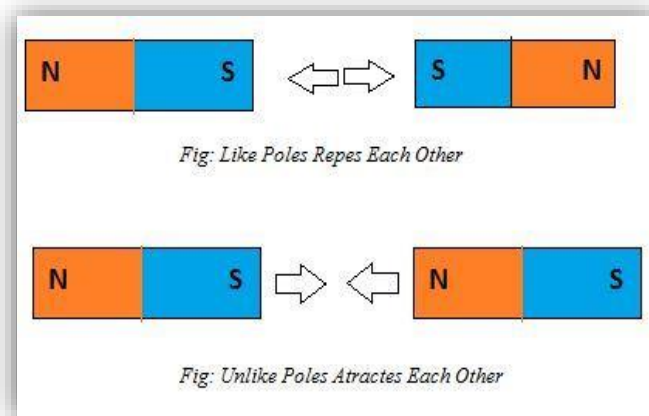

Fig 1) Principle of magnet

### 2. PRINCIPLE OF ELECTROMAGNET

Electric current flowing through a wire wound around an iron nail creates a magnetic field, which caused an iron nail to become a temporary magnet. The nail can then be used to pick up paper clips. When the electric current is cut off, the nail loses its magnetic property and the paper clips fall off. The students will make an electromagnet that will attract a paper clip. They will then increase the strength of an electromagnet (improve on their initial design) so that it will attract an increased number of paper clips. The participants will also compare the properties of magnets and electromagnets.[6]

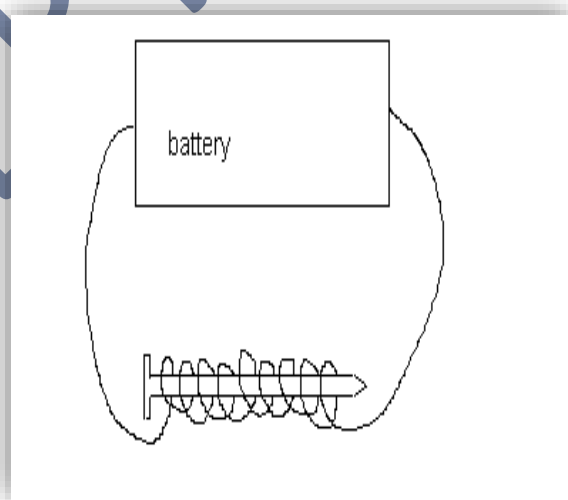

Fig.2) conceptual diagram of electromagnet

**DESIGN**

**DRAWING OF ENGINE MODEL**

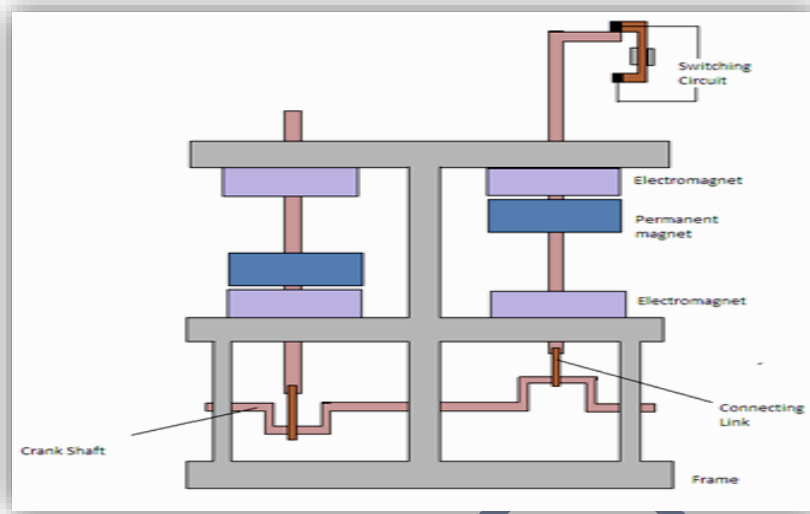

Fig 3): Model of Magnetic Engine

This design consists of two permanent magnets [4] and one electromagnet on either side as shown above. The electromagnets are fixed to the frame and the permanent magnets are mounted on shaft, where shaft is free to reciprocate. The electromagnets are provided with DC power source. To change the polarity of the electromagnet the switching circuit used as shown in fig.

**CIRCUIT DIAGRAM FOR CHANGING THE POLARITY:**

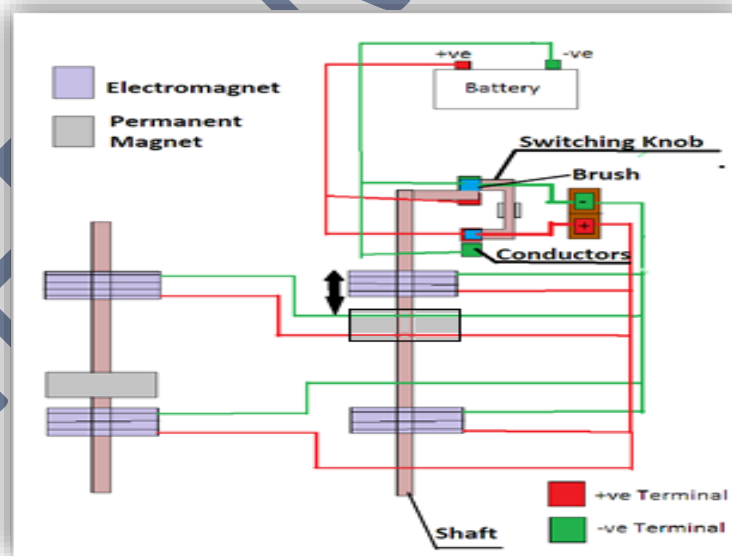

Fig 4): Circuit Diagram

Above fig shows the circuit diagram of the switching ckt. It is mainly consist of the switching knob. The switching knob is free to reciprocate along the conductor. The blue point on the knob indicates the brushes while the red and green are the conductors. The brushes are further connected to the distributor from where the current is distributed to all the electromagnet. This switch will reduce all the complications regard to use of sensors and relays.

### WORKING OF ENGINE:

Consider figure 3 & 4 for the working of magnetic engine: Current figure show the position in which permanent magnet at right side is at TDC and left one is at BDC. At this position right side shaft push the knob to move upward and switch the terminal and changes the polarity. At this position electromagnet and permanent magnet closure to each other are have same polarity hence there is repulsion at the same time there will be attraction between electromagnet and permanent magnet which are more far to each other. When permanent magnet at right side comes to BDC same shaft will push switching knob to change the current direction which will change the polarity. This will cause the successive repulsion and attraction.

### CALCULATIONS

Input voltage = 12 V

Input current = 5 A

Input Power = Voltage × Current = 12 × 5 = 60W Max.

Force exerted by electromagnet on piston

$$F_1 = (N^2 I^2 K A) / 2G^2$$

Where,

N = number of turns = 450

I = Current flowing through coil = 5 A

K = Permeability of free space =  $4\pi \times 10^{-7}$

A = Cross-sectional area of electromagnet  
 = 20 × 35 mm<sup>2</sup>

G = Least distance between electromagnet and permanent magnet = 0.001 m

On substitution, we get

Max. Force  $F_1 = 74.95\text{N}$

Force exerted by permanent magnet Force

$$F_2 = (B^2 A) / 2\mu_0$$

Where,

B = Flux density (T)

A = Cross-sectional area of magnet = 0.0942 m

$\mu_0$  = Permeability of free space =  $4\pi \times 10^{-7}$

Now flux density

$$B = 0.2547\text{ T}$$

Now substituting B in the equation of force,

$$F_2 = 24.67\text{ N}$$

Since, force  $F_1$  and  $F_2$  are repulsive,

Total force  $F = F_1 + F_2$

$$F = 99.62\text{ N}$$

## CONCLUSION

Very less amount of electric power is required to magnetize the electromagnets and these electromagnets can supply the sufficient amount of power continuously. On the other hand this mechanism is pollution free & has no bad environmental impact. Here, it is proved that it can produce sufficient amount of power. So, it is very much acceptable in environmental & pollution aspect.

## REFERENCES

- [1] Prof. V Ganesan, Internal Combustion Engine 2<sup>nd</sup> Edition, Tata McGraw - Hill Publishing Limited (page no.2,3,4,5,6)
- [2] Electro-Magnetic Reciprocating Engine By Charles J. Van Depoel'E, Of Lynn, Assachusetts United States Patent Office 1893.
- [3] Concept Of An Electromagnetic Solar Based Power Drive For Automobile by Shirsendu Dasand Amit Kumar: International Journal of Advanced Science and Technology Vol.76 (2015)ISSN: 2005-4238
- [4] A Paper On "Methods Of Magnetizing Permanent Magnets" by Joseph Stupak
- [5] David halliday, Robert Resnick & Kenneth s. Krane, Physics vol.2 5<sup>th</sup> edition., John Wiley & on's, inc publication; (page no.727)
- [6] Leonie Boshoff - Mostert, Electromagnet, Electromagnets Script Version 3.0 University of Nebraska