

# NUMERICAL INVESTIGATION OF SLOPED BUILDING FOR SEISMIC RESPONSES

RAGURAMAN V.

Department of Civil Engineering, Sri Guru Institute of Technology  
Coimbatore, India

## ABSTRACT

The structures constructed in mountain areas are most affect to seismic loads in compare to the structures that are construct in plain regions. Buildings on slides not same as other buildings hence they are not same in vertical and horizontal were torsion moments are tends to more collapse when subjected to dynamic force. The columns are situated at base are having unequal heights because of the sliding surface. In this work, performance of two floor slides frame having varying column heights is analyzed for ground motion with different slide angles i.e.,  $0^\circ, 5^\circ, 10^\circ$  and  $15^\circ, 20^\circ, 25^\circ$ . The analysis are done using software ETABS 2015 by performing a static linear analysis. From the concluded work, it has been found that as the slide angle increases, stiffness of the model increases due to decrease in height of short column and that results in increase of earthquake loads on small column. Therefore proper analysis is required to rectify the defects of various ground slopes.

## INTRODUCTION

### GENERAL

Earthquake is maximum disastrous and unpredictable phenomenon of nature. Were a building is tends to seismic loads it does not cause loss to human lives directly but the damage cause to the structures that starts to the collapse of structure and hence to the occupants and the property.

Normally the buildings are constructed on hilly regions are not same as the constructing structures in flat surfaces. This because of the irregularities in the dimensions.

### OBJECTIVE

The aim of this project is to study experimentally and numerically the behaviour of sloped building respect to lateral movement and earthquake excitations.

The performance of a sloped building belongs on frequency of the lateral force as it affects its behaviour when it is goes with ground movement. In this study numerical work is done by varying sloping angle.

### SCOPE

The scope of this work is summarized as follows:

1. A two storyed one bay frame is taken for static behaviour study to determine the intensity at the short columns.
2. Linear static behaviour is performed using software tool i.e., ETABS 2015 as per spectra of IS 1893 (Part 1):2002 for 5 % damping at medium soil.

## NUMERICAL INVESTIGATION

This loading is meant to simulate inertia forces due to only the horizontal portion of the seismic action, ignoring the vertical portion altogether. While the applied lateral forces increase in the course of analysis, the engineer can follow the gradual emergence of plastic hinges, the evolution of plastic mechanism and damage, as a function of the magnitude of the imposed lateral loads and of the resulting displacements.

Unlike linear or non-linear dynamic analysis, which both give directly all peak seismic demands under a given earthquake, a pushover analysis per se gives only the capacity curve. The demand has to be estimated separately. This is done in terms of the highest displacement caused by the lateral forces, either to the same SDOF system or at the holding node of the entire structure. This is called "target displacement".

It is required to perform pushover until a terminal point at 1.5 times the "target displacement". Target displacement can be determined by any of the following methods:

- (i) Capacity Spectrum Method
- (ii) Displacement Coefficient Method
- (iii) N2 Method

### SOFTWARE USED

For analysis, ETABS 2015 to be used. ETABS 2015 can clear typical issues like Static behaviour, Seismic study and Natural frequency. These type of problem can be solved by ETABS with the help of IS-CODE.

### COLLECTION OF DATA

- The following datas are to be assumed.
- Seismic zone : zone 3 (0.36)
- Clause of soil : medium soil (clause 2)
- Damping ratio : 5%
- Foundation type : Rigid

In analysis work , The following terms are considered.

- ✓ Fixed base
- ✓ Response spectrum

### INPUT DATA

#### Load case details

The load cases used in our analysis are showed below.

Dead: linear static

Live: linear static

Lcase: response spectrum

#### Section details

- For the Analysis work , we consider a slab as cold formed plate section and column as MS Flat rods.
- ❖ C.F Plates : 300 x 150mm  
3mm thickness
- ❖ MS flat rod : 25mm  
3mm thickness

### ANALYSIS OF FLAT SURFACE

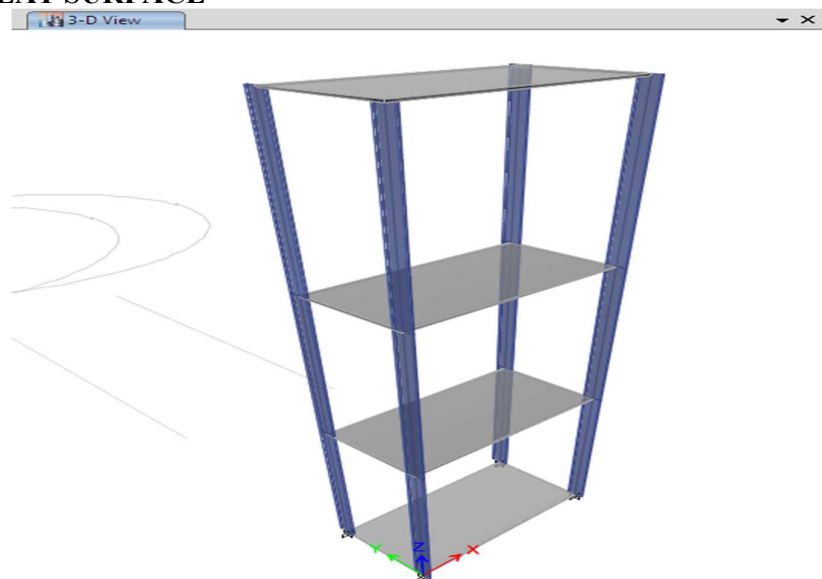

Fig. Flat model frame

Table . storey data (flat surface)

Name	Height mm	Elevation mm	Master Story	Similar To	Splice Story
Story3	300	900	Yes	None	No
Story2	300	600	No	Story3	No
Story1	300	300	No	Story3	No
Base	0	0	No	None	No

## DISPLACEMENT

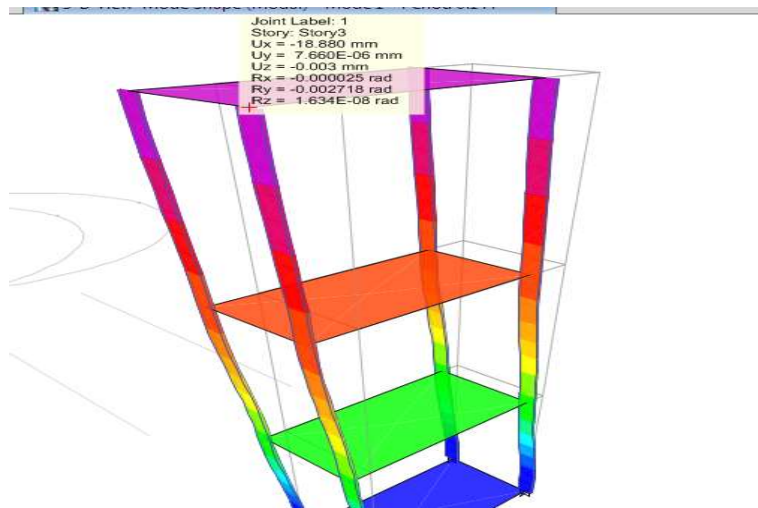

Fig. Displacement of flat surface

## Frequency

Modal Periods and Frequencies						
Case	Mode	Period sec	Frequency cyc/sec	Circular Frequency	Eigenvalue rad <sup>2</sup> /sec <sup>2</sup>	
Modal	1	0.144	6.922	43.4949	1891.802	
Modal	2	0.053	18.966	119.1657	14200.4602	
Modal	3	0.05	20.194	126.8856	16099.9563	
Modal	4	0.036	27.973	175.7607	30891.8347	
Modal	5	0.033	30.622	192.4011	37018.177	
Modal	6	0.012	82.857	520.606	271030.575	
Modal	7	0.009	105.968	665.8168	443312.0445	
Modal	8	0.005	195.842	1230.5131	1514162	
Modal	9	0.004	224.002	1407.4457	1980903	
Modal	10	0.000414	2415.631	15177.8581	230367376	
Modal	11	0.0004139	2415.953	15179.8819	230428814	
Modal	12	0.0003703	2700.752	16969.3229	287957921	

Fig. Frequency of flat model

**ANALYSIS OF 5 DEG FRAME MODEL**

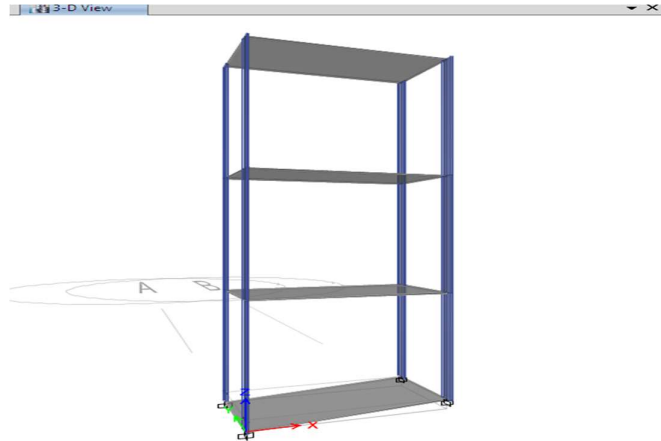

Fig.Model frame(5 deg)

Table. storey data ( 5deg model )

Name	Height mm	Elevation mm	Master Story	Similar To	Splice Story
Story4	300	900	Yes	None	No
Story3	300	600	No	Story4	No
Story2	273.8	300	No	Story4	No
Story1	26.2	26.2	No	Story4	No
Base	0	0	No	None	No

**Displacement**

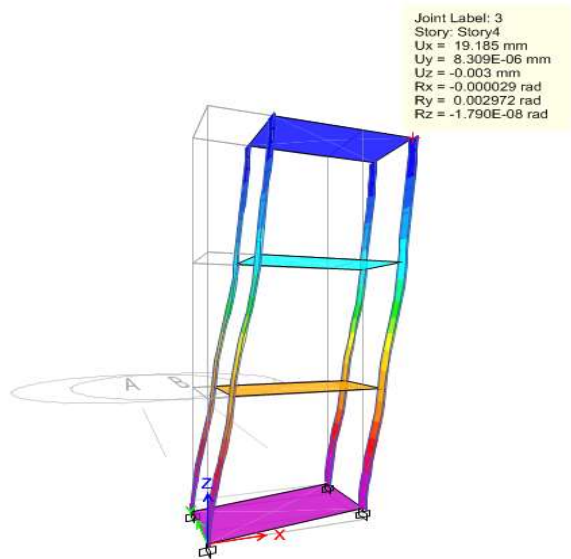

Fig.Displacement of 5 deg model

## Frequency

Modal Periods and Frequencies						
Case	Mode	Period sec	Frequency cyc./sec	Circular Frequency	Eigenvalue rad <sup>2</sup> /sec <sup>2</sup>	
Modal	1	0.14	7.159	44.9793	2023.1394	
Modal	2	0.052	19.341	121.5227	14767.7591	
Modal	3	0.048	20.821	130.8243	17114.9869	
Modal	4	0.035	28.587	179.6167	32262.1718	
Modal	5	0.032	31.078	195.2672	38129.2661	
Modal	6	0.012	85.02	534.1983	285367.7768	
Modal	7	0.009	109.13	685.6852	470164.1402	
Modal	8	0.005	200.897	1262.2761	1593341	
Modal	9	0.004	230.932	1450.9857	2105359	
Modal	10	0.001	847.822	5327.0235	28377179	
Modal	11	0.001	850.343	5342.8645	28546201	
Modal	12	0.0004139	2415.781	15178.8016	230396017	

Fig.Frequency of 5 deg model

## ANALYSIS OF 10 DEG MODEL FRAME

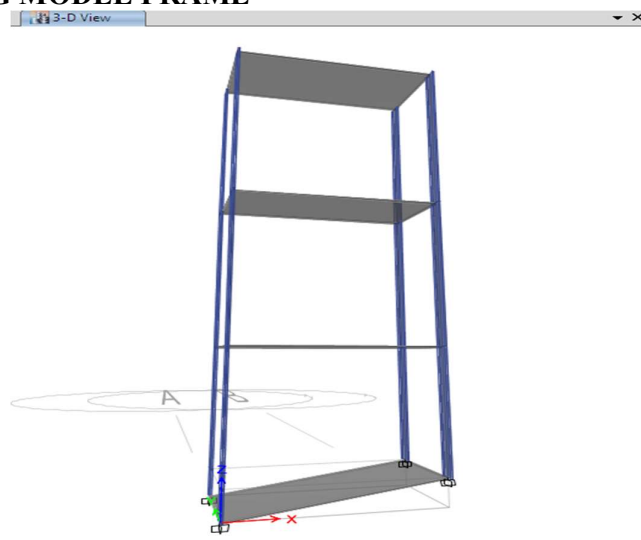

Fig.4.7. Model frame (10 deg)

Table.storey data ( 10 deg model )

Name	Height mm	Elevation mm	Master Story	Similar To	Splice Story
Story4	300	900	Yes	None	No
Story3	300	600	No	Story4	No
Story2	247.1	300	No	Story4	No
Story1	52.9	52.9	No	Story4	No
Base	0	0	No	None	No

**Displacement**

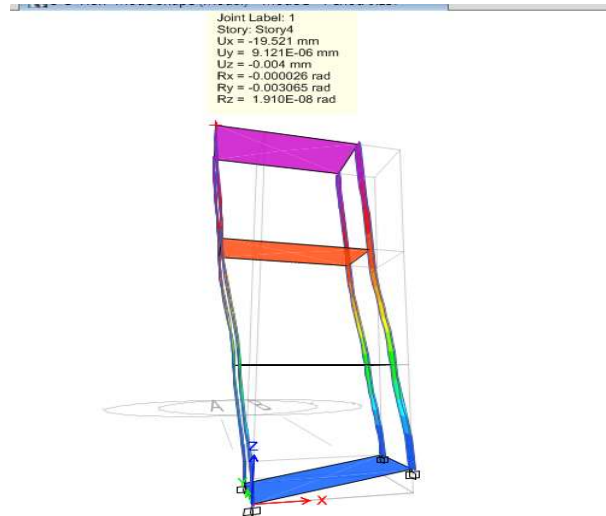

Fig.Displacement of 10 deg model

**Model frequency**

Modal Periods and Frequencies						
Case	Mode	Period sec	Frequency cyc/sec	Circular Frequency	Eigenvalue rad <sup>2</sup> /sec <sup>2</sup>	
Modal	1	0.137	7.307	45.9088	2107.6213	
Modal	2	0.051	19.433	122.0988	14908.1266	
Modal	3	0.047	21.167	132.9973	17688.2915	
Modal	4	0.035	28.968	182.011	33128.0184	
Modal	5	0.032	31.028	194.9551	38007.4954	
Modal	6	0.012	85.227	535.4946	286754.4306	
Modal	7	0.009	111.068	697.863	487012.7231	
Modal	8	0.005	200.533	1259.9865	1587566	
Modal	9	0.004	236.7	1487.2295	2211852	
Modal	10	0.003	333.723	2096.8463	4396764	
Modal	11	0.003	335.986	2111.065	4456595	
Modal	12	0.0004139	2415.769	15178.726	230393724	

Fig 4.9.Frequency of 10 deg model

**4.8 ANALYSIS OF 15 DEG MODEL FRAME**

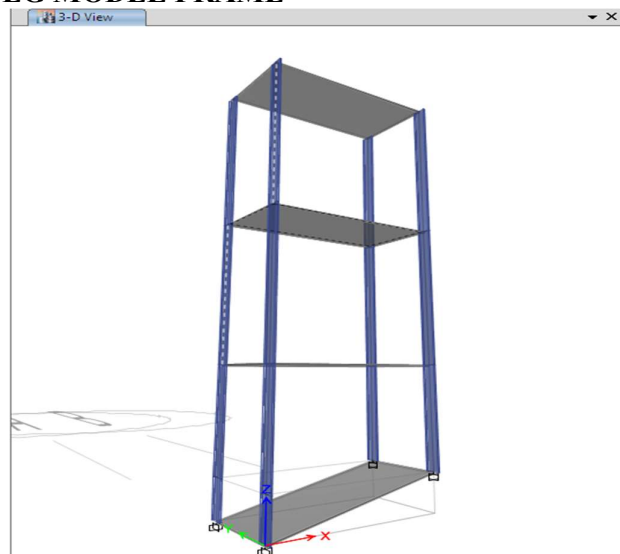

Fig .Model frame ( 15 deg )

Table. storey data ( 15 deg model )

Name	Height mm	Elevation mm	Master Story	Similar To	Splice Story
Story4	300	900	Yes	None	No
Story3	300	600	No	Story4	No
Story2	219.6	300	No	Story4	No
Story1	80.4	80.4	No	Story4	No
Base	0	0	No	None	No

**Displacement**

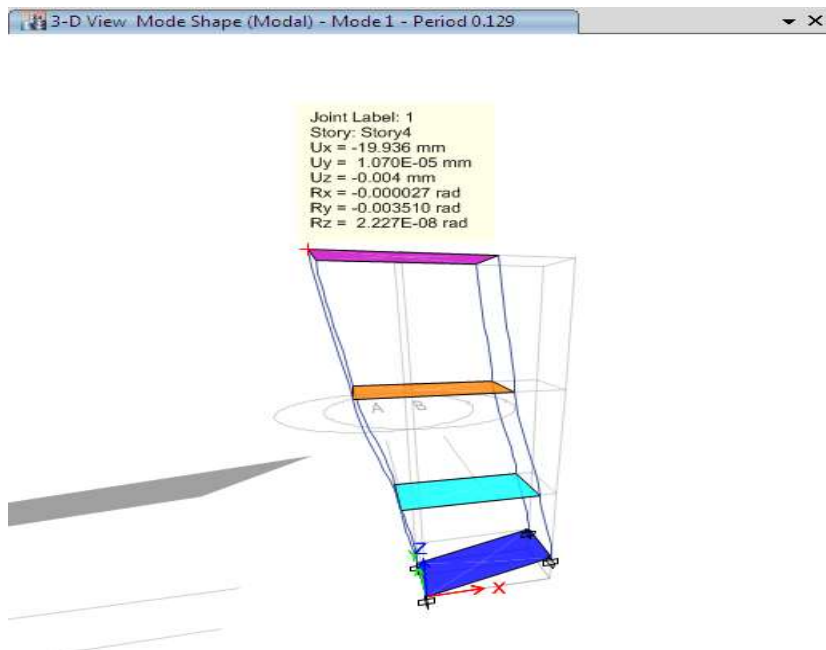

Fig. Displacement of 15 deg model frame

**Frequency**

Modal Periods and Frequencies						
Case	Mode	Period sec	Frequency cyc/sec	Circular Frequency	Eigenvalue rad <sup>2</sup> /sec <sup>2</sup>	
Modal	1	0.129	7.756	48.7339	2374.9966	
Modal	2	0.05	20.052	125.9913	15873.8123	
Modal	3	0.044	22.543	141.6424	20062.581	
Modal	4	0.033	30.043	188.7695	36633.5415	
Modal	5	0.03	32.889	206.6481	42703.4168	
Modal	6	0.011	88.642	556.9511	310194.5575	
Modal	7	0.009	117.482	738.1586	544878.1103	
Modal	8	0.005	207.959	1306.645	1707321	
Modal	9	0.005	215.245	1352.4241	1829051	
Modal	10	0.005	217.235	1364.9301	1863034	
Modal	11	0.004	260.583	1637.29	2680718	
Modal	12	0.001	1633.902	10266.108	105392973	

Fig.frequency of 15 deg model

**ANALYSIS OF 20 DEG MODEL FRAME**

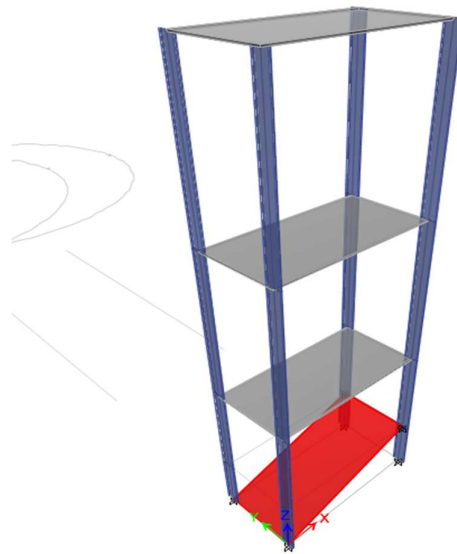

Fig.Model frame (20 deg )

Table. storey data (20 deg model)

Name	Height mm	Elevation mm	Master Story	Similar To	Splice Story
Story4	300	900	Yes	None	No
Story3	300	600	No	Story4	No
Story2	190.8	300	No	Story4	No
Story1	109.2	109.2	No	Story4	No
Base	0	0	No	None	No

**Displacement**

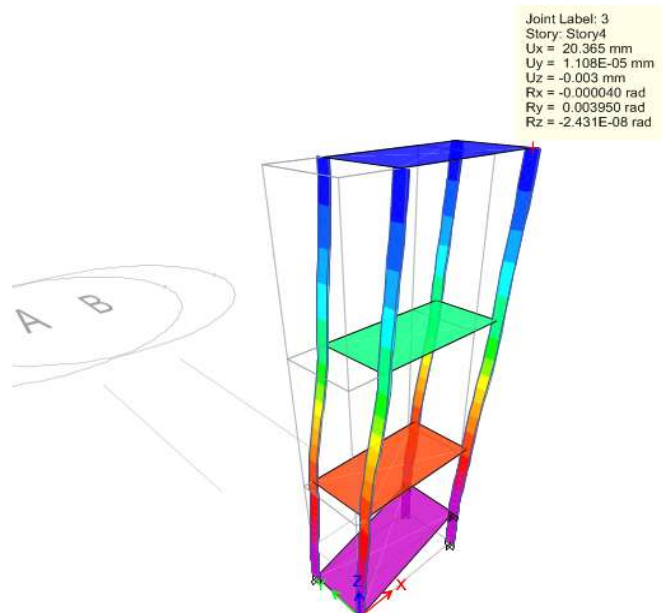

Fig .Displacement of 20 deg model



## Frequency

Modal Periods and Frequencies						
Case	Mode	Period sec	Frequency cyc/sec	Circular Frequency	Eigenvalue rad <sup>2</sup> /sec <sup>2</sup>	
Modal	1	0.125	7.984	50.1667	2516.7022	
Modal	2	0.05	20.121	126.426	15983.5229	
Modal	3	0.043	23.167	145.5633	21188.6806	
Modal	4	0.033	30.596	192.2399	36956.1735	
Modal	5	0.029	34.085	214.1639	45866.196	
Modal	6	0.011	88.33	554.9934	308017.7157	
Modal	7	0.008	120.498	757.1133	573220.5924	
Modal	8	0.006	159.997	1005.2889	1010606	
Modal	9	0.006	163.702	1028.5689	1057954	
Modal	10	0.005	206.192	1295.5424	1678430	
Modal	11	0.004	283.066	1778.5536	3163253	
Modal	12	0.001	1226.819	7708.3341	59418414	

Fig.Frequency of 20 deg model

## ANALYSIS OF 25 DEG MODEL FRAME

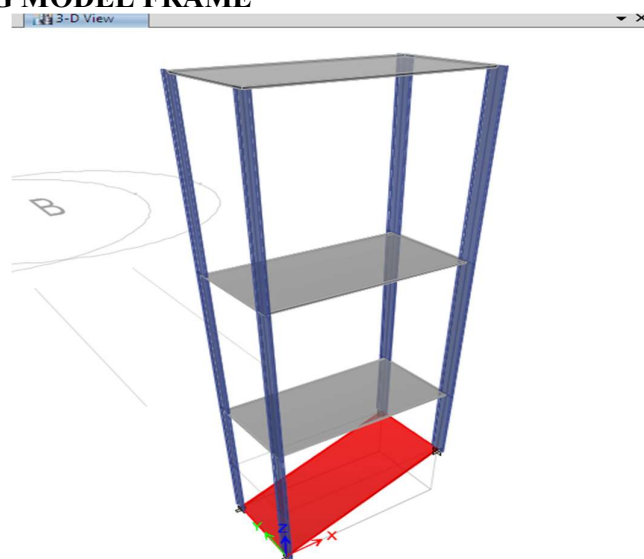

Fig. model frame ( 25 deg )

Table. storey data ( 25 deg )

Name	Height mm	Elevation mm	Master Story	Similar To	Splice Story
Story4	300	900	Yes	None	No
Story3	300	600	No	Story4	No
Story2	160.1	300	No	Story4	No
Story1	139.9	139.9	No	Story4	No
Base	0	0	No	None	No

**Displacement**

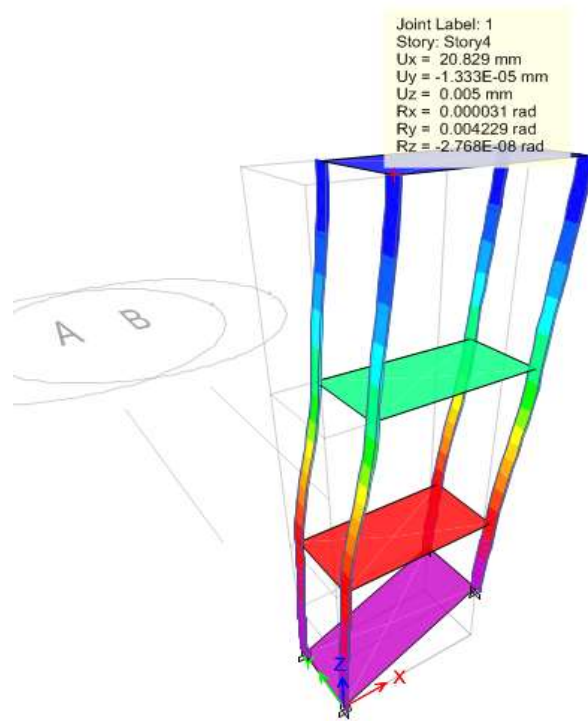

Fig.Displacement of 25 deg model

**Frequency**

Modal Periods and Frequencies

1 of 12 | Reload Apply

	Case	Mode	Period sec	Frequency cyc/sec	Circular Frequency	Eigenvalue rad <sup>2</sup> /sec <sup>2</sup>
▶	Modal	1	0.119	8.379	52.6483	2771.8453
	Modal	2	0.049	20.473	128.6367	16547.3946
	Modal	3	0.041	24.262	152.4437	23239.068
	Modal	4	0.032	31.608	198.5963	39440.4784
	Modal	5	0.026	37.961	238.5157	56889.7411
	Modal	6	0.011	89.556	562.6946	316625.1644
	Modal	7	0.008	126.123	792.4533	627982.192
	Modal	8	0.007	139.542	876.7671	768720.6305
	Modal	9	0.007	144.993	911.017	829951.9743
	Modal	10	0.005	207.214	1301.9626	1695107
	Modal	11	0.003	330.621	2077.3534	4315397
	Modal	12	0.001	1060.895	6665.7997	44432886

Fig.Frequency of 25 deg model

## COMPARISON OF NUMERICAL RESULTS

The numerical results (Displacement, frequency) are compared and showed below.

Table.Comparison of results

Configuration	Displacement (mm)	Frequency
Flat	18.88	6.92
5 deg	19.18	7.15
10 deg	19.58	7.30
15 deg	19.94	7.76
20 deg	20.37	7.99
25 deg	21.01	8.39

## CONCLUSION

### FLAT SURFACE

- From the flat surface model, the displacements are greater at top storey.
- The responses are gradually increased at each story upto first mode.
- After the maximum displacement from mode 1, the responses are suddenly decreased to initial level.

### SLOPED SURFACE

- The maximum responses are achieved from the frequency of 7.5 Hz.
- At every story, the base observes maximum response compared to flat model. This because of its short column effect.
- After the mode 1, the responses are not suddenly decreased like flat surface, instead it gradually decreasing at each increase in frequency.
- Hence the responses are still high in sloped surface.
- In the slope surface, the maximum responses are constantly observed from base (ch 1) and top of the story (ch 4).
- In sloped surface model, the displacements are 82% greater compared to flat surface model.

## REFERENCES

- 1) Ravikumar, C. M., Babu Narayan, K. S., 2012 "Effect of Irregular Configurations on Seismic Vulnerability of RC Buildings" Architecture Research, 2(3):2026DOI:10.5923/j.arch.02
- 2) Shuyan, J. et al., "Analysis of factors influencing dynamic characteristics of building structures on slope", Proceedings of the 8th International Conference on Structural Dynamics, EUROLYN 2011.
- 3) Singh, Y. and Phani, G., "Seismic Behaviour of Buildings Located on Slopes" - An Analytical Study and Some Observations From Sikkim Earthquake of September 18, 2011. 15th World Conference on Earthquake Engineering Journal 2012.
- 4) Sreerama, A. K. and Ramancharla, P. K., "Earthquake behaviour of reinforced concrete framed buildings on hill slopes", International Symposium on New Technologies for Urban Safety of Mega Cities in Asia (USMCA 2013), Report No: IIIT/TR/2013/-1.
- 5) "Structural Analysis And Design (ETABS 2015) software" Bentley Systems, Inc.
- 6) Patel, M. U. F. et al., "A Performance study and seismic evaluation of RC frame buildings on sloping ground" IOSR Journal of Mechanical and Civil Engineering (IOSR-JMCE) e-ISSN: 2278-1684, p-ISSN: 2320-334X-, PP 51-58, 2014.

- 7) Prashant, D., Jagadish, K. G., “Seismic Response of one way slope RC frame building with soft storey” International Journal of Emerging Trends in Engineering and Development Issue 3, Vol.5 (September 2013).
- 8) Nagargoje, S. M. and Sable, K. S., “Seismic performance of multi-storeyed building on sloping ground”, Elixir International Journal, December 7, 2012.
- 9) Khadiranaikar, R. B. and Masali, A., “Seismic performance of buildings resting on sloping ground-A
- 10) Review”, IOSR Journal of Mechanical and Civil Engineering, e-ISSN: 2278-1684,p-ISSN: 2320-334X, Volume 11, Issue 3 Ver. III (May- Jun. 2014), PP 12-19.
- 11) Fajfar, P., “A nonlinear analysis method for performance based seismic design”, Earthquake Spectra, vol. 16, No. 3, pp. 573-592, 2000.
- 12) Chopra, A.K. and Goel, R.K., “A modal pushover analysis procedure for estimating seismic demands for buildings”, Earthquake Engineering and Structural Dynamics, vol. 31, No. 3, pp. 561-582, 2002.
- 13) Babu, N. J. and Balaji, K.Y.G.D, “Pushover analysis of unsymmetrical framed structures on sloping ground” International Journal of Civil, Structural, Environmental and Infrastructure Engineering Research and Development (IJCSEIERD) ISSN 2249-6866 Vol. 2 Issue 4 Dec - 2012 45-54.
- 14) Agarwal, P. K. and Shrikhande, M. “Earthquake Resistant Design of Structure” Fourth Edition, Prentice Hall 2006.
- 15) Ashwani, K., Pushplata, “Building Regulations for Hill Towns of India”, HBRC Journal, 2014.