

# ANALYSIS OF TUNED FILTERS FOR MITIGATION OF HARMONIC CURRENT DISTORTION OF RESIDENTIAL LOAD

Yogesh Bhujbal  
*M.E. Scholar Department of Electrical G.H.I.E.R.T,  
S.F. Pune University, Pune*

Prof. P.N. Korde  
*Head of Electrical Department G.H.I.E.R.T,  
S.F. Pune University, Pune*

## ABSTRACT

Harmonics are the by-products of modern electronic devices that are nonlinear loads which create harmonics by drawing current in rather than smooth sinusoidal manner. Any distribution circuit feeding nonlinear loads will contain some degree of harmonic frequencies. Due to the rapidly increasing number of non-linear loads in distribution systems, the harmonic distortion of the current and voltage increases. Non-linear loads are personal computer, television set (TV), fluorescent tube with electronic ballast, compact fluorescent lamp, battery charger, uninterrupter power supply (UPS) and any other equipment powered by switched-mode power supply (SMPS) unit. The harmonic distortion produced in residential buildings has not been given proper attention as linear loads were predominant earlier. As the number of harmonics-producing loads in residences has increased over the years, it has become increasingly necessary to address their effects on the distribution system. Power Quality of distribution networks is affected due to the flow of generated harmonics. Harmonic currents generated by nonlinear loads can cause problems on equipments of distribution network. These harmonics can cause excessive heat in many appliances, and hence reduce the life span of the distribution transformer supplying such loads. It can also increase power consumption and reduce system efficiency. It also lowers the power factor, resulting in penalties to consumers. In this paper presents the results of a SIMULINK of harmonic distortion caused by non linear home appliances on bus bar and then it compensated by filter. The scope of work includes analysis of percentage of total harmonic distortions before and after compensation and found reduced percentage of THD after the compensation. Percentage of distortions are compensated using 3<sup>rd</sup> and 5<sup>th</sup> harmonic filter and these filters are directly connected to the 0.4kv feeder (PCC) from which three phases are split with neutral to home appliances.

**Keywords:** %THD, Non linear load, Matlab-Simulink, TDD, FFT tool, PCC, Filter, Power quality.

## INTRODUCTION

Electric utilities are concerned about decreasing power quality and its potential impacts on the grid. As residential customers add more electronics to the home and replace existing mechanical switching equipments by electronic switching equipments, there is a concern that local grid stability could be compromised. In an effort to determine how residential power quality (as measured by power factor and total harmonic distortion) is changing over time, Advanced Energy proposed to survey the current research on residential power quality and measure actual power quality for two residential homes of different ages under different load conditions[6][1]. Harmonic distortion is the distortion of either the voltage or current waveform with the addition of frequencies other than the fundamental 50 Hertz frequency. Harmonics are generated by non-linear loads such as computers, battery charging systems, variable frequency drives and other electronic equipment. Total harmonic distortion indicates the combined impact of all harmonics upon the fundamental waveform. Since utilities provide a 50 Hertz voltage source of electricity, the voltage waveform supplied is fairly constant. Various loads on the grid can, however, impact the current waveform. The primary concern in residential locations are the third harmonic and other triplens ( $3^{\text{rd}}$ ,  $9^{\text{th}}$ ,  $15^{\text{th}}$ , etc.) harmonics. Each harmonic exists at a multiple of the fundamental frequency. Many of these harmonics can cancel each other out. Triplen harmonics, however, are additive and will combine with each other, as well as the fundamental frequency, to have more deteriorating impacts.

## BLOCK RESIDENTIAL LOAD

In block diagram shows that incoming three phase supply are connected to PCC. Capacity of PCC is 0.4 KV. Three phase manual circuit breaker connected between loads and PCC. In between PCC and manual circuit breaker  $3^{\text{rd}}$  and  $5^{\text{th}}$  harmonic filter are connected. Purpose of this filter is that from analysis  $3^{\text{rd}}$  and  $5^{\text{th}}$  harmonics current harmonics magnitude are more in residential load [10]. Single phases 230v carried out from PCC by neutral. On each phase various modern home appliances are connect and analyze the emission of harmonics from it.

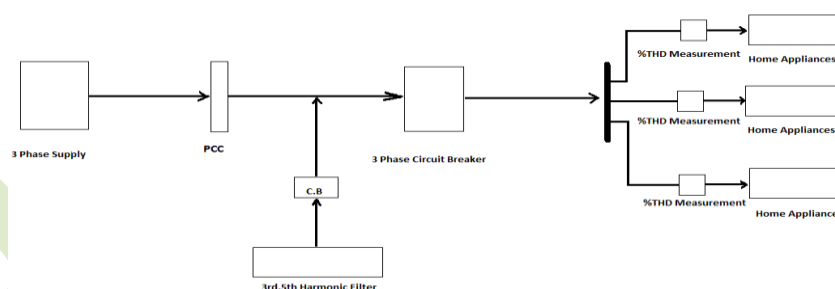

Figure 1: Block Diagram Residential load Harmonic Analysis

## COMPOSED MODEL RESIDENTIAL LOADS IN SIMULINK

Modeled composed in Matlab - Simulink 2015a as in fig 2. There are numbers of home appliance blocks are connected in parallel on each phase. Blocks are composed in Simulink from standards circuit diagrams.

As shown in composed model, consider there are three phase voltage get from transformer and its phase to line voltage is 400V. Three phase line then connected to distribution feeder in which measured the Voltage and current. After distribution feeder three phases are isolated into three single phases. Each phase connected to Home1, Home2 and Home3 of Phase A, Phase B and Phase C respectively with the neutral and get voltage 230V.

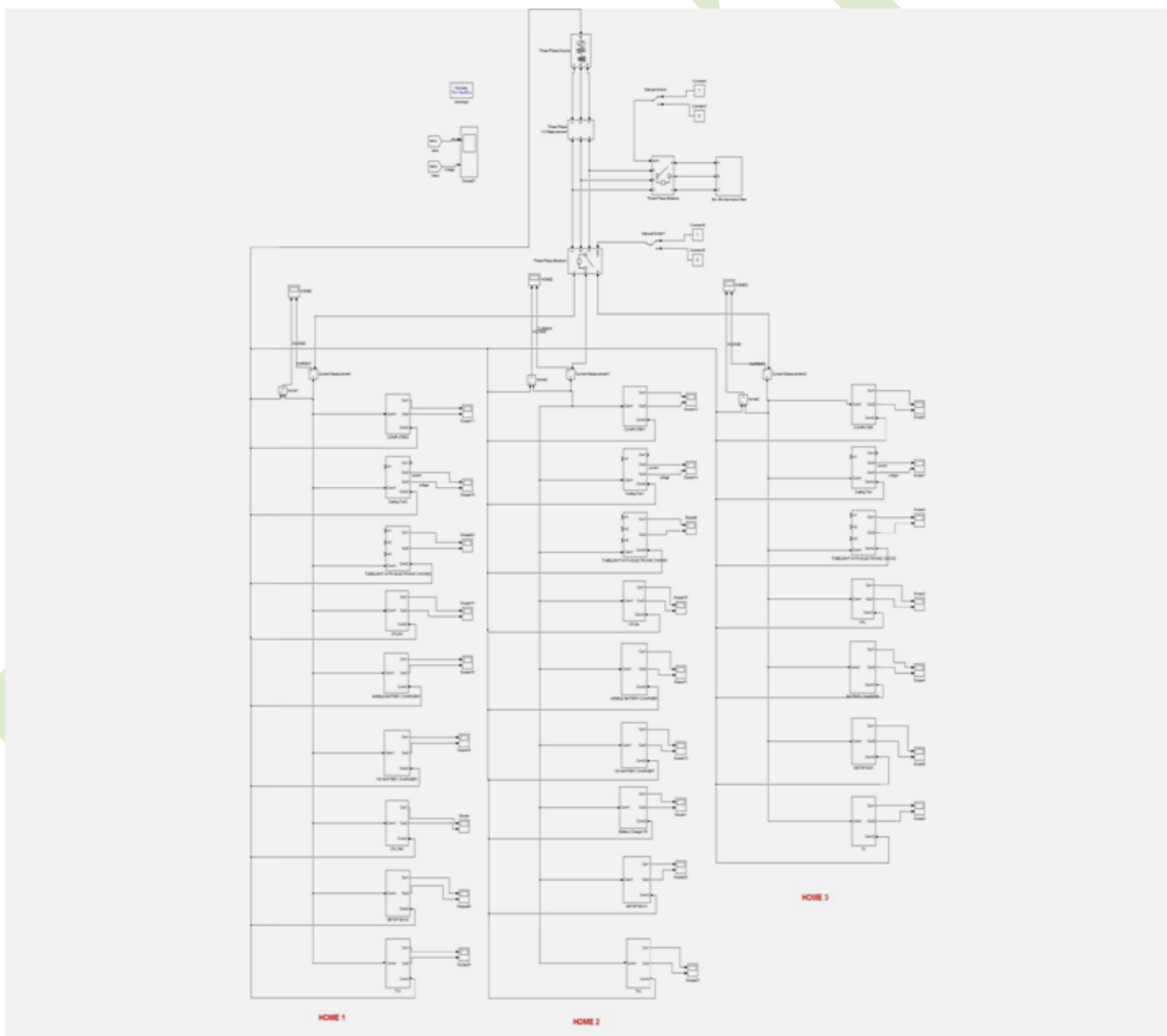

Figure 2: Schematic composed model residential loads in Simulink

Specification of connected blocks of home appliances as follows:

- |   |   |
|---|---|
| <p>A. Setop Box(SMPS)<br/>Input – 230V, I = 0.7 A 50 Hz<br/>Output- DC 12 V, 2A</p> <p>B. Battery Charger 12V<br/>Input – 230V, I = 0.7 A 50 Hz<br/>Output- DC 12 V, 2A</p> <p>C. Battery Charger 5V(Mobile<br/>Charger)<br/>Input – 230V, I = 0.15 A 50 Hz<br/>Output - DC 5 V, 2A</p> | <p>D. Battery Charger 24V(Laptop<br/>Charger)<br/>Input – 230V, I = 0.15 A 50 Hz<br/>Output - DC 5 V, 2A</p> <p>E. Compact Fluorescent Lamp (CFL<br/>11W)<br/>Input – 230 V, I=0.55A, 50Hz</p> <p>F. Compact Fluorescent Lamp (CFL<br/>15W)<br/>Input – 230 V, I=0.8A, 50 Hz.</p> |
|---|---|

### IEEE Standards

International Electro-technical Commission (IEC) is the widely recognized organization as the curator of electric power quality standards. IEC has introduced a series of standards, to deal with power quality issues. Integer and inter harmonics are included in IEC61000 series as one of conducted low-frequency electro-magnetic phenomena. The series also provides internationally accepted information for the control of power system harmonic (and inter-harmonic) distortion. The IEEE 519-1992 standard is a widespread alternative to the IEC series ( $I_{sc}$ - short circuit current).

Table 1: IEEE 519-1992 standards

$I_{sc} / I_t$	<11	11 ≤ h < 17	≤ h < 23	≤ h < 35	≤ h	TDD
<20	4.0	2.0	1.5	0.6	0.3	5.0
20<50	7.0	3.5	2.5	1.0	0.5	8.0
50<100	10.0	4.5	4.0	1.5	0.7	12.0
100<1000	12.0	5.5	5.0	2.0	1.0	15.0
>1000	15.0	7.0	6.0	2.5	1.4	20.0

**Total harmonic distortion (THD) Calculation**

$$THD_I = \frac{1}{i_1} \sqrt{i_{rms}^2 - i_1^2} \times 100\% \quad (1)$$

$$THD_V = \frac{1}{v_1} \sqrt{v_{rms}^2 - v_1^2} \times 100\% \quad (2)$$

$$THD_{Total} = \sqrt{THD^2_1 + THD^2_2 + THD^2_0} \times 100\% \quad (3)$$

**FILTERS**

Assuming negligible resistive part, the angular frequency series resonance circuit can be determined by the equation (4)

$$\omega_0 = \frac{1}{\sqrt{LC}} = 2\pi f_0 = \frac{2\pi}{T_0} \quad (4)$$

In this equation the behavior of the impedances and their angles of two filters tuned to the frequencies for the 3<sup>rd</sup> and 5<sup>th</sup> harmonic orders respectively are illustrated in figures 3 and 4.

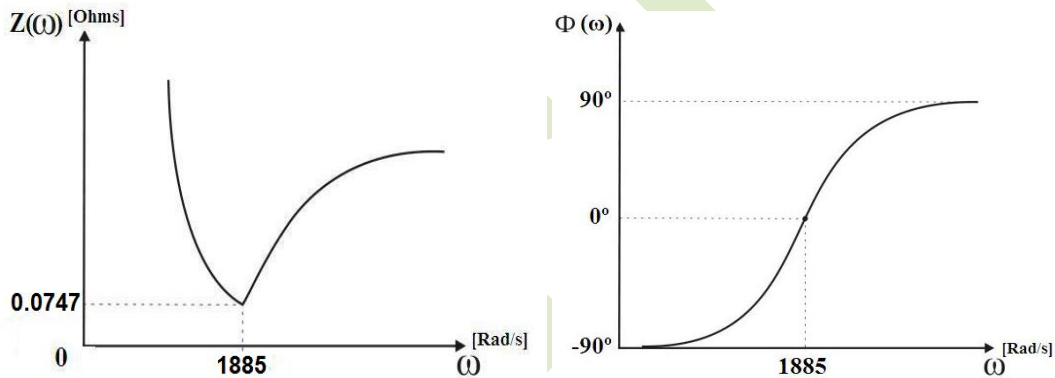

Figure 3: Magnitude and angle of the impedance of a series RLC circuit versus frequency for 5th harmonic order [2].

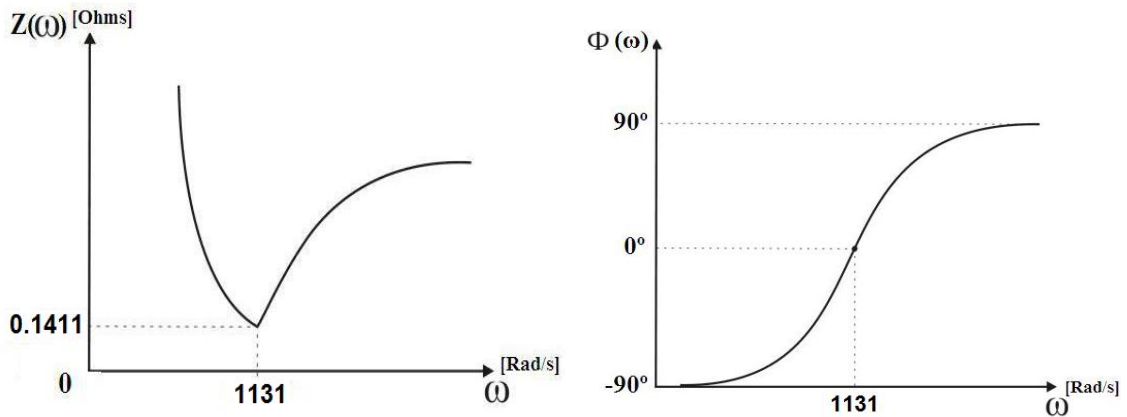

Figure 4: Magnitude and angle of the impedance of a series RLC circuit versus frequency for 3rd harmonic order [2]

For the calculation of the basic filter is necessary to define the quality factor (Q) which determines the selectivity of the filter and whose variation range that goes from 20 to 40. Closer to 40, more selective is the Q the filter and closer to 20, greater the extent of the filter at harmonic frequencies surrounding the frequency tuning, as evidenced by figure 5,

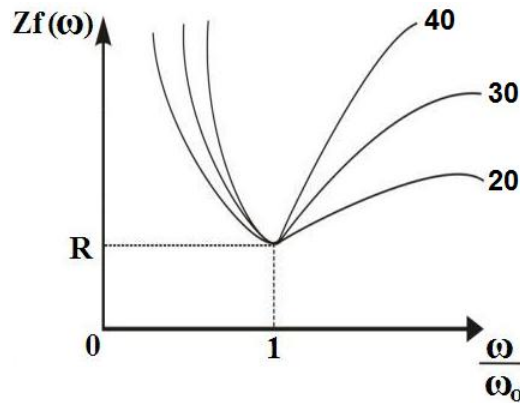

Figure 5: Impedance versus frequency for different values of Q factor [2].

### DESIGN OF FILTER

The electrical parameters used for the design of filters using *Matlab* tuned in 5<sup>th</sup> and 3<sup>rd</sup> harmonic orders are presented in table 10. They were obtained by simulation of the modeled system in SIMULINK of figure 26. We chose a quality factor Q equal to 30 for providing a good selectivity for the harmonic frequencies in question.

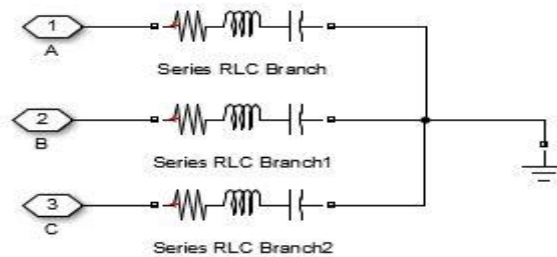

Figure 6 : Design of 3<sup>rd</sup> and 5<sup>th</sup> Harmonic filter

Table 2 3<sup>rd</sup> and 5<sup>th</sup> Harmonic Filter parameters

Order	3 <sup>rd</sup> and 5 <sup>th</sup> Harmonic
Resistance ( $\Omega$ )	2.5
Inductance(mH)	3.7423
Capacitance( $\mu H$ )	208.897

**CONNECTION OF FILTER**

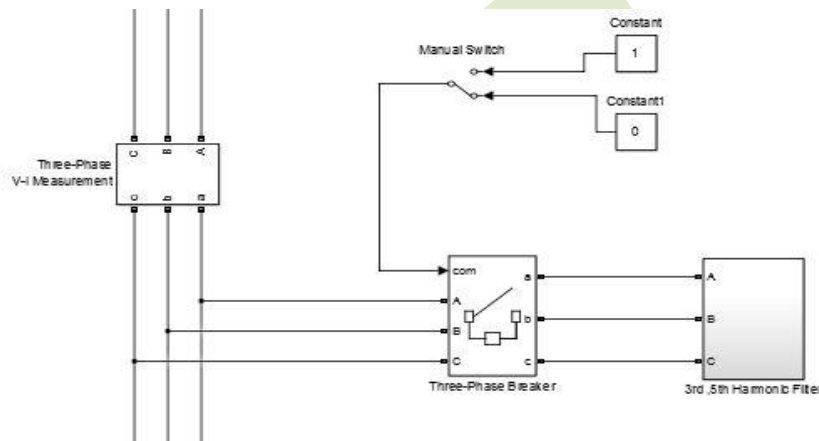

Figure 7: Connection of filter

After insertion of filters in the system illustrated in composed diagram using the software Matlab Simulink, there was a decrease in the content of the 5<sup>th</sup> and 3<sup>rd</sup> harmonic orders of 0.4KV distribution system as shown in figure 7 which illustrates the waveforms of the currents in phases A, B and C and whose effective values of the multiple frequencies is illustrated in the spectrogram of figure 9

Table 3 Comparative of total current harmonic distortions (a) before (b) after the presence of tuned filters of 5th and 3rd harmonic orders (THD %).

<b>Before Compensation</b>			
<b>THD</b>	<b>%THD<sub>A</sub></b>	<b>%THD<sub>B</sub></b>	<b>%THD<sub>C</sub></b>
Current	40.62	37.24	43.19
Voltage	4.67	4.71	7.48

(a)

<b>After Compensation</b>			
<b>THD</b>	<b>%THD<sub>A</sub></b>	<b>%THD<sub>B</sub></b>	<b>%THD<sub>C</sub></b>
Current	3.86	4.11	6.39
Voltage	3.54	3.61	5.93

(b)

**SIMULATION RESULTS**

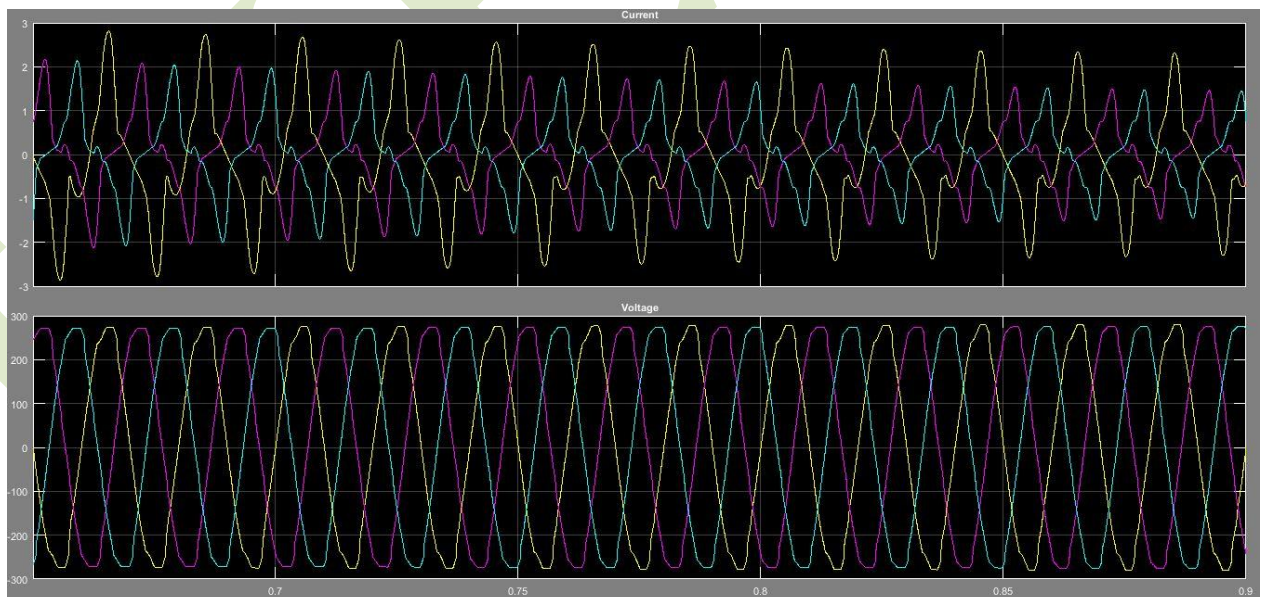

Figure 8: Simulated Waveforms of the currents and Voltage at feeder0.4KV before Compensation



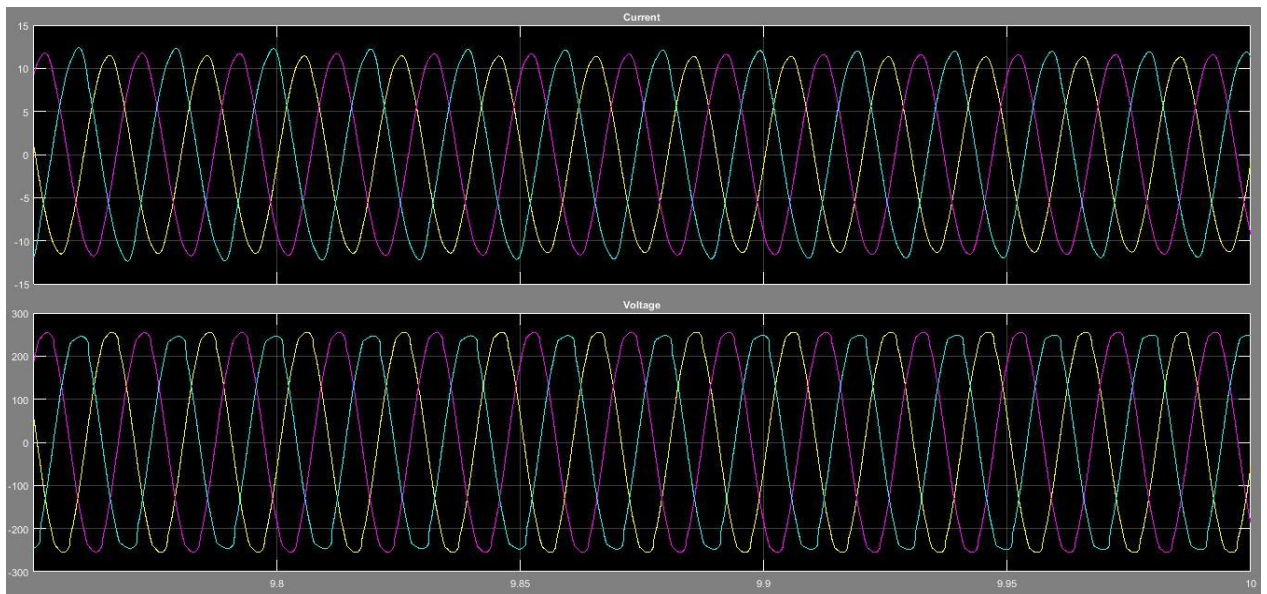

Figure 9: Simulated Waveforms of the currents and Voltage at feeder 0.4KV after Compensation

In figure 8 current waveform are not smooth sinusoidal it content harmonic current in phase A , phase B and phase C. %THD are shown in table 3(a). Voltage harmonics are minimum because voltage magnitudes are more.

In figure 9 shows current waveforms are smooth sinusoidal because waveform are tuned by 3<sup>rd</sup> 5<sup>th</sup> harmonic filter. Reduced percentages of harmonics are shown in table 3(b). After the compensation the percentages of harmonics are nearer to TDD as per the IEEE519-1992 as shown in table 1.

## CONCLUSION

Concludes from above analysis, insertion of 3<sup>rd</sup> and 5<sup>th</sup> harmonic filter in series the current harmonic can be minimizing up to 90% on bus bar. %THD of current was 22.84%, 22.73%, 37% but after compensation it gets 1.61%, 1.96, 4.10% at Phase A, Phase B and Phase C respectively. Reduced current harmonics means flow of rms current in the networks are minimum and effect due to excessive current can be reduced. This is simplest method and low cost method of compensation and power quality of distribution can be improved in this way.

## REFERENCES

- [1] A. B. Vasconcellos, Dr., M. S. C. de Carvalho, Acad., J. R. de Carvalho, Acad., A. M. Coimbra, Acad., R. C. F. Gregory., Acad.; Raul V. A. Monteiro “*Energy Efficiency and Harmonic Distortion in Automation of Air Conditioning*” ©2014 IEEE.

- [2] Arnulfo B. de Vasconcellos, Dr., Marina S. C. de Carvalho, Acad., Andrei M. Coimbra, Acad., Jéssica R. de Carvalho, Acad., Raul V. A. Monteiro, Esp. “*Analysis of Tuned Filters for Mitigation of Harmonic Current Distortion of Air Conditioning Systems to Inverter*” 2014 IEEE
- [3] J. Niitsoo, I. Palu, J. Kilter, P. Taklaja, T. Vaimann. “*Residential Load Harmonics in Distribution Grid*” 3rd International Conference on Electric Power and Energy Conversion Systems, Yildiz Technical University, Istanbul, Turkey, October 2-4, 2013 IEEE.
- [4] MOK Yan, Kit, TSE C.F. Norman, LAU W.H. “*A Study on the Effects of Voltage Distortion on Current Harmonics Generated By Modern SMPS Driven Home Appliances in Smart Grid Network*” IEEE2012.
- [5] Agus Purwadi, Nana Heryana, Dadan Nurafiat “*A Study of Harmonic Impacts on High Voltage, Medium Voltage and Low Voltage Networks in PT. PLN Distribution System*”, Indonesia ©2011 IEEE.
- [6] Khodijah Mohamed, Hussain Shareef, Azah Mohamed Malaysia. “*Analysis of Harmonic Emission from Dimmable Compact Fluorescent Lamps*” International Conference on Electrical Engineering and Informatics 17-19 July 2011, Bandung, Indonesia ©2011 IEEE.
- [7] Ranjana Singh, Amarjit Singh “*Energy Loss Due to Harmonics in Residential Campus – A Case Study. UPEC2010 31st Aug - 3rd Sept IEEE 2010.*”
- [8] Jing Yong, Member, IEEE, Liang Chen, and Shuangyan Chen “*Modeling of Home Appliances for Power Distribution System Harmonic Analysis*” IEEE Transactions On Power Delivery, OCTOBER 2010.
- [9] V. KatiC\*, B. DumniC\*, S. Mujovic", J.RadoviC\*\*\* “*Effects of Low Power Electronics & Computer Equipment Forecast*”. International Conference on Industrial Technology (ICIT), 2004 IEEE.
- [10] Yogesh Bhujbal, Prof. Ravindra Joshi, Amol Chate “*Analysis and Simulation Of Harmonics For Various Residential Loads Using Simulink*” [IJIERT] ISSN: 2394-3696 VOLUME 2, ISSUE 8, AUG-2015.