

# FLOW DISTRIBUTION NETWORK ANALYSIS FOR DISCHARGE SIDE OF CENTRIFUGAL PUMP

**Satish M. Rajmane**

*Research Scholar,*

*WIT Research Center, Solapur University, Solapur, India*

**Dr. S. P. Kallurkar**

*Principal,*

*Atharva College of Engineering, Mumbai, India*

## ABSTRACT

A computational fluid dynamics (CFD) analysis has been conducted to find the pressure losses for dividing and combining fluid flow through a junction of discharge system. Simulations are performed for a range of flow ratios and equations are developed for pressure loss coefficients at junctions. A mathematical model based on successive approximations then would be employed to estimate the pressure losses. The proposed CFD based strategy can be used for the analysis of all the three pipe branches of some diameter are selected along with equal length so that only the effect of bend angle can be studied. The effect of bend angle, pipe diameter, pipe length, Reynolds number on the resistance coefficient is studied. The software used is CATIA for modeling and ANSYS fluent for analysis purpose.

## INTRODUCTION

Centrifugal pumps are a sub-class of dynamic axis symmetric work absorbing turbo machinery. Centrifugal pumps are used to transport fluids by the conversion of rotational kinetic energy to the hydrodynamic energy of the fluid flow. The rotational energy typically comes from an engine or electric motor. The fluid enters the pump impeller along or near to the rotating axis and is accelerated by the impeller, flowing radially outward into a diffuser or volute chamber (casing), from where it exits. Common uses include water, sewage, petroleum and petrochemical pumping. The reverse function of the centrifugal pump is a water turbine converting potential energy of water pressure into mechanical rotational energy.

A computational fluid dynamics (CFD) analysis has been conducted to find the pressure losses for dividing and combining fluid flow through a junction of discharge system. Simulations are performed for a range of flow ratios and equations are developed for pressure loss coefficients at junctions. A mathematical model based on successive approximations then would be employed to estimate the pressure losses. The proposed CFD based strategy can be used as a substitute to setting up and performing costly experiments for estimating junction losses.

In this section a review of research work in the area of different inserts was carried out and based on this review certain observation were made;

**Abdul Waheed Badar, Reiner Buchholz, Yongsheng Lou and Felix Ziegler**<sup>[1]</sup> have studied the A CFD analysis has been conducted to find the pressure losses for dividing and combining fluid flow through a tee junction of a solar collector manifold. Simulations are performed for a range of flow ratios and Reynolds numbers, and equations are developed for pressure loss coefficients at junctions. A theoretical model based on successive approximations then is employed to estimate the isothermal and non-isothermal flow

distribution in laminar range through a collector consisting of 60 vacuum tubes connected in parallel in a reverse and parallel flow arrangement.

**Chris Smith** <sup>[2]</sup> have investigated using CFD in flow assurance Analysis of low material temperatures caused by rapid gas expansion (JT cooling) is possible using CFD. This includes cold spots and thermal gradients, which can go beyond the design limits of the material, and traditional pipeline tools don't give the distinction required. Situations can be evaluated including choke valves and downstream pipe work at start-up, and process equipment and pipe work during blow down.

**R. Vijayakumar, S.N. Singh, V. Seshadri** <sup>[3]</sup> has studied Unbalanced coal/air flow in the pipe system feeding the boilers will lead to non uniform combustion in the furnace thereby lowering the efficiency of the power plant.. The current practice of balancing the flow by introducing orifices in the pipe system is generally achieved using semi-empirical methods. This paper presents the CFD analysis for deciding the optimum geometry of the orifices to balance the flow in the existing power plant at NTPC.

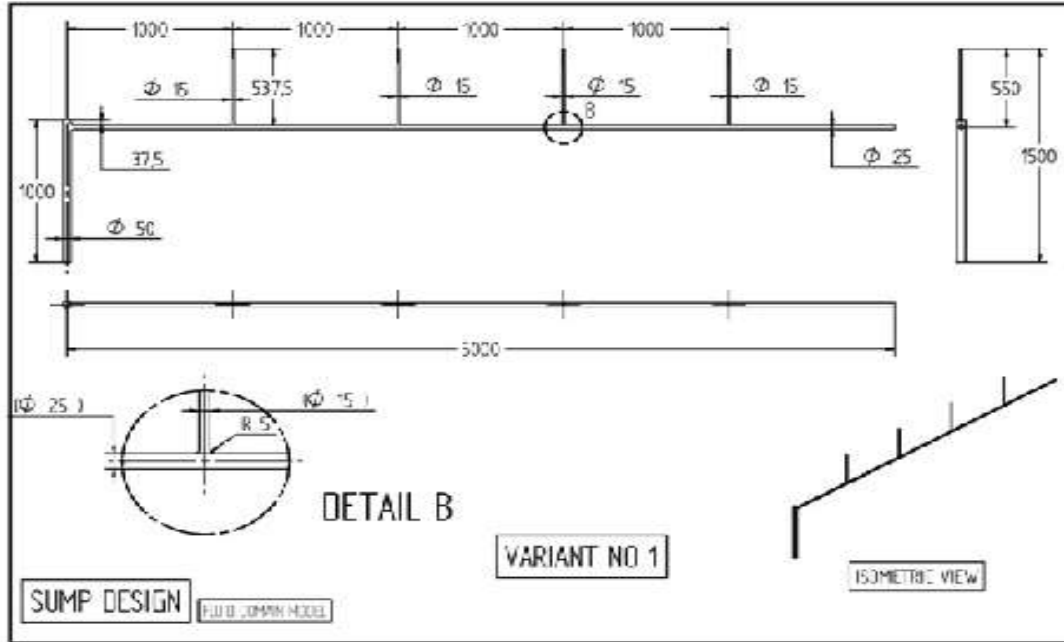
**Balvinder Singh, Harpreet Singh, Satbir Singh Sehgal** <sup>[4]</sup> the objective of this study was to Pipe fittings are used in the plumbing systems to connect straight pipe or tubing sections for regulating or measuring fluid flow. The wye shape fitting will convert into T shape fitting. In the present work, effect of angle of turn/bend for a Y-shape pipe will be studied computationally. Water and air as a fluid is selected which flows through the plumbing system. The effect of bend angle, pipe diameter, pipe length, Reynolds number on the resistance coefficient is studied. It was observed that resistance coefficient vary with the change in flow parameters.

**S. Mokhtari, V.V. Kudriavtsev, M. Danna** <sup>[5]</sup> has studied uniformly of a dielectric film deposited on the silicon wafers greatly depends on the flow delivery systems & injector geometry. In this paper, we analyze flow distribution patterns through the simulated closed-end multiple outlet pipe/channel which delivers chemical precursors to the parallel slot linear injector of a chemical vapor deposition reactor. Instead of using semiempirical formulas for the flow resistance & flow network methodology, a finite difference multi-block CFD solution method is used to calculate local pressure patterns in the pipe & establish flow distribution trends & uniformly as a function of Re number & system aspect ratio. It was found that flow distribution changes qualitatively as we move from the low Re flow conditions to intermediate & high Re flow regimes.

## DRAWING AND ANALYTICAL CALCULATION

### A) DRAWING:-

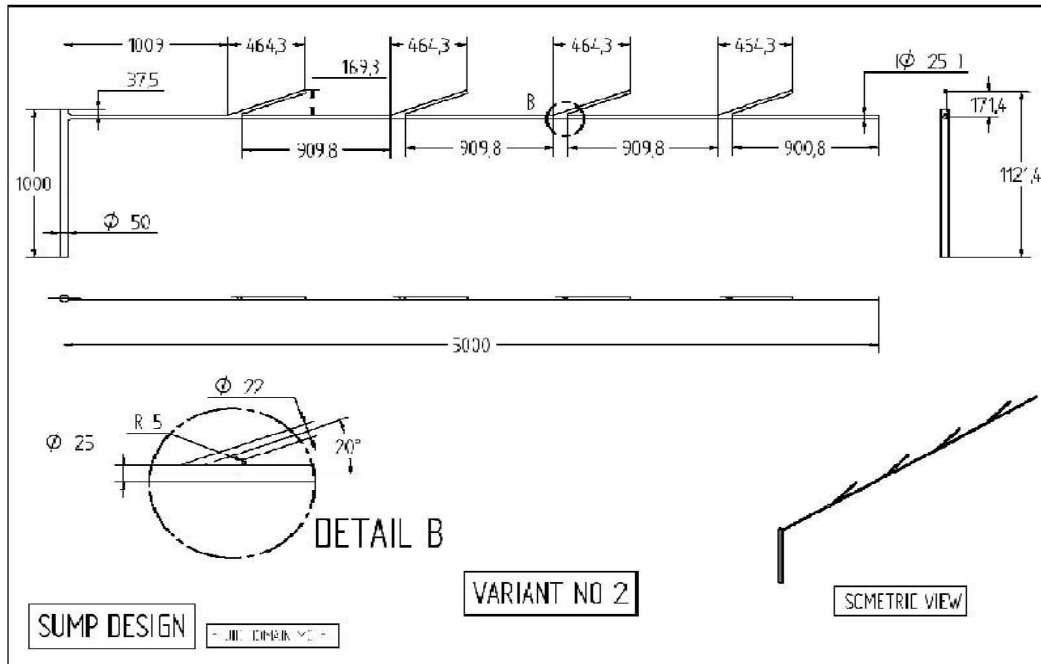
Variant No. 1:-



**Fig. 1 Variant No. 1**

Variant No. 2:-

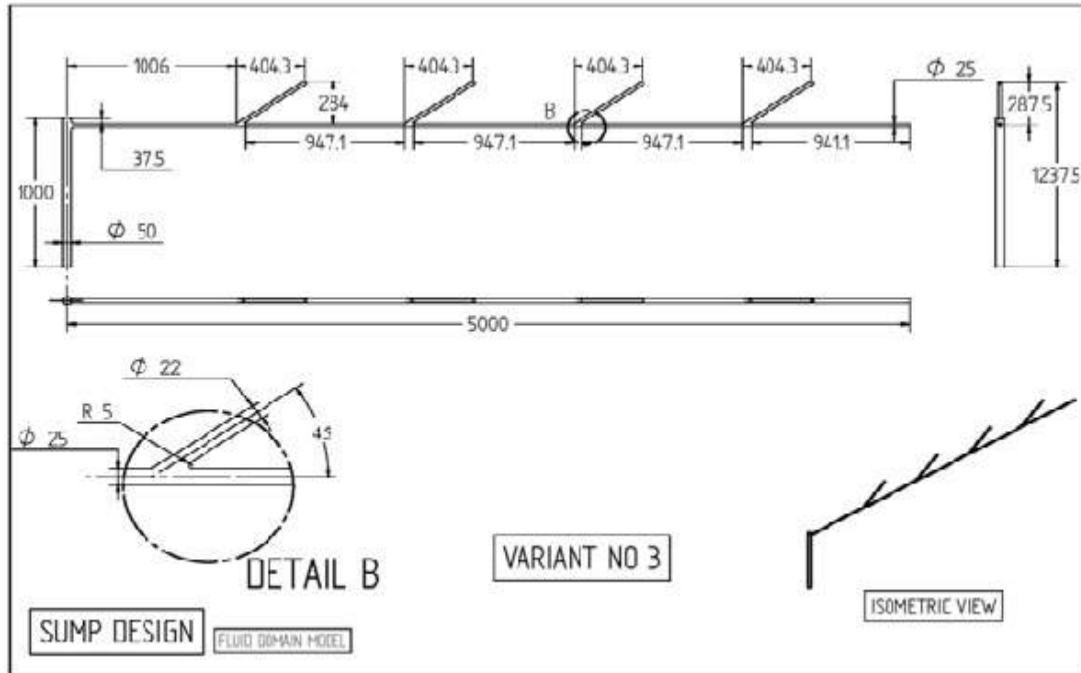
Design for the variant with angel of 20 degree:-



**Fig. 2 Variant No. 2**

Variant No. 3:-

Design for the variant with angle 45 degree:-



**Fig. 3 Variant No. 3**

**B) ANALYTICAL CALCULATIONS:-**

Single Pipe:-

Given Data:-Inner diameter of pipe ( $d_i$ ) = 50 mm

Thickness of pipe ( $t$ ) = 1.7 mm

$$\therefore \text{Internal Diameter } d_i = d_o - 2t$$

$$\therefore d_o = 50 + 2 \times 3.9$$

$$\therefore d_o = 57.8 \text{ mm}$$

Length of pipe ( $l$ ) = 1m

Mass of flowing water per second = 40 kg/sec

Density of flowing water ( $\rho_w$ ) = 1000 kg/m<sup>3</sup>

Weight Density of carbon steel ( $\rho_{cs}$ ) = 7850 kg/m<sup>3</sup>

Coefficient of friction for pipe ( $\mu$ ) = 0.005

Efficiency of motor ( $\eta$ ) = 80%

a) Cross-sectional area of pipe:

$$a = \frac{\pi}{4} \times d_i^2$$

$$\therefore a = \frac{\pi}{4} \times (50 \times 10^{-3})^2$$

$$\therefore a = 0.001963 \text{ m}^2$$

b) Velocity of flowing liquid in pipe per second:

*mass = density of water  $\times$  area  $\times$  velocity*

$$\therefore \text{velocity, } v = \frac{\text{mass}}{\text{area} \times \text{density of water}}$$

$$\therefore v = \frac{40}{0.001963 \times 1000}$$

$$\therefore v = 20.376 \text{ m/sec}$$

c) Major losses in pipe :

$$h_f = \frac{4flv^2}{2gd_o}$$

$$\therefore h_f = \frac{4 \times 0.005 \times 1 \times 20.376^2}{2 \times 9.81 \times 50 \times 10^{-3}}$$

$$\therefore h_f = 8.46 \text{ m}$$

d) Pressure developed in a pipe

$$p_d = \rho_w g h_f$$

$$\therefore p_d = 1000 \times 9.81 \times 8.46$$

$$\therefore p_d = 82992.6 \text{ N/m}^2$$

e) Weight of single pipe:

$$w = \text{specific weight} \times \text{volume}$$

$$\therefore w = \text{specific weight} \times \text{area} \times \text{length}$$

$$\therefore w = \rho_{cs} \times \frac{\pi}{4} (d_o^2 - d_i^2) \times l$$

$$\therefore w = 7850 \times \frac{\pi}{4} [(57.8 \times 10^{-3})^2 - (50 \times 10^{-3})^2] \times 1$$

$$\therefore w = 20.72 \text{ kg}$$

f) Power required to pump water:

$$p = \frac{\rho_w Q g h_f}{\eta}$$

$$\therefore p = \frac{1000 \times (40/1000) \times 9.81 \times 8.46}{0.8}$$

$$p = 4149.63 \text{ Kw}$$

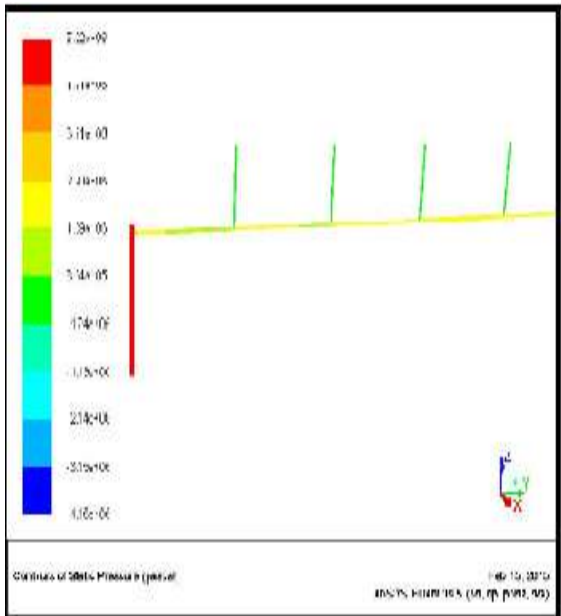
## FINITE ELEMENT ANALYSIS

We briefly examine the function of each of these elements within the context of a CFD code. Before going for those processes we have to identify the problem; in that first includes define area means exactly for which result we looking for (i.e. pressure drop, mass flow rate, temperature drop etc.). Second things come that is identification of domain in which exact part of complete system have to identify by which expected result (i.e. pressure drop, mass flow rate, temperature drop etc.) will affect and try to examine that part only instead of complete system because it takes long time for simulation and required large memory space in computer system unnecessary.

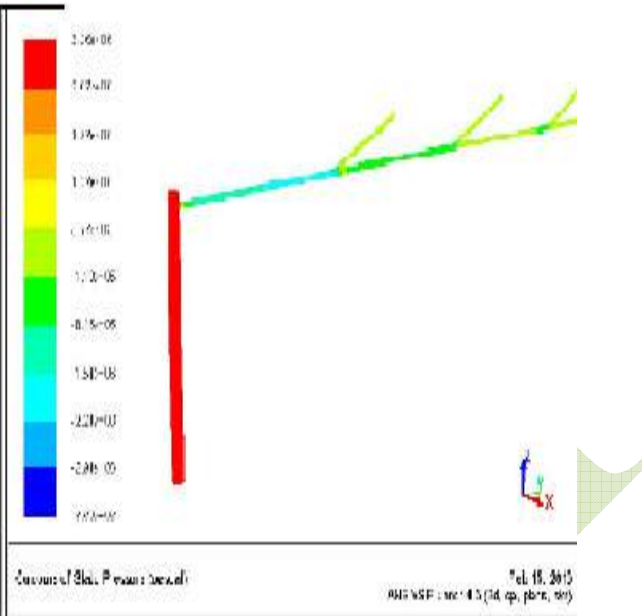
For solving we are using ANSYS Fluent Solver. In this interface following parameters used:

- System type: Pressure Based system
- Analysis type: Steady state condition
- Model: k-epsilon (2 equations) with realizable model
- Fluid Used: Water
- Mass flow rate at inlet: 2 kg/s
- Temperature: 27 deg<sup>0</sup>C.

Pressure Plot:-

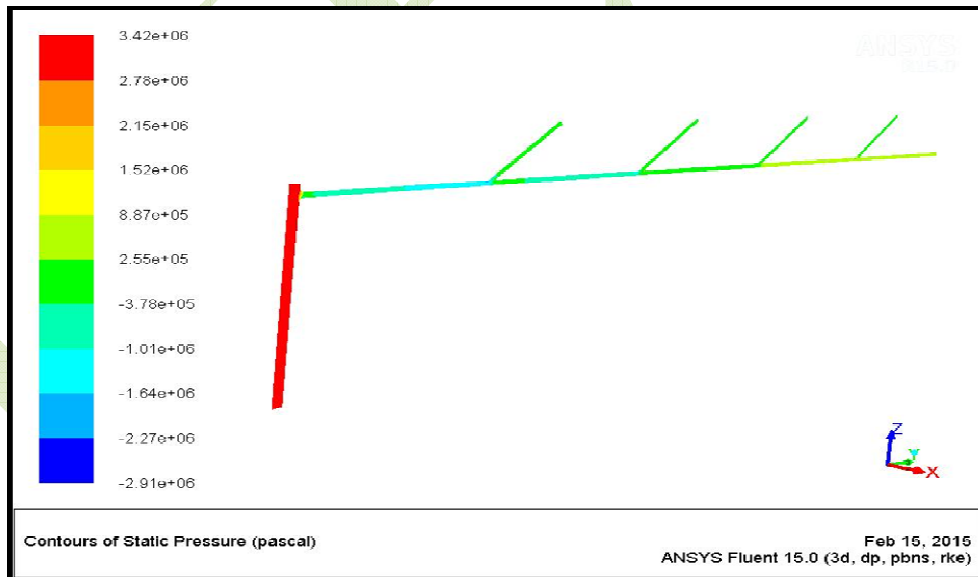


**Fig. 4 ANSYS Variant 1**



**Fig. 5 ANSYS Variant 2**

Fig shows that pressure plot in Pascal. At inlet is more and decreases as gradually along the length. Color strip shows indicate the different pressure level. Blue color indicates the minimum pressure level and red color indicate the max pressure level.

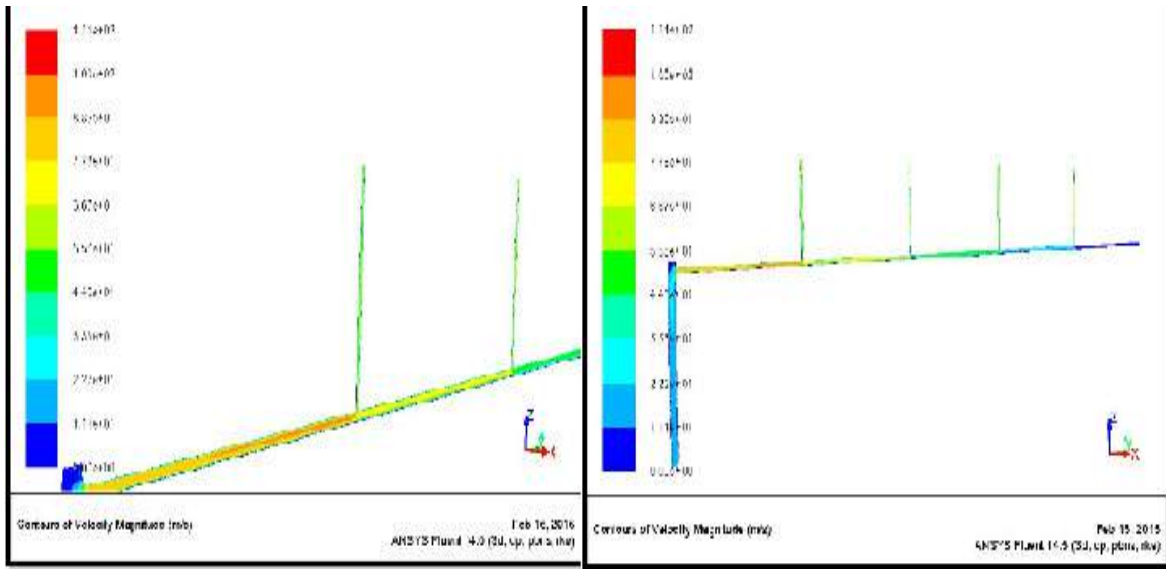


**Fig. 6 ANSYS Variant 3**



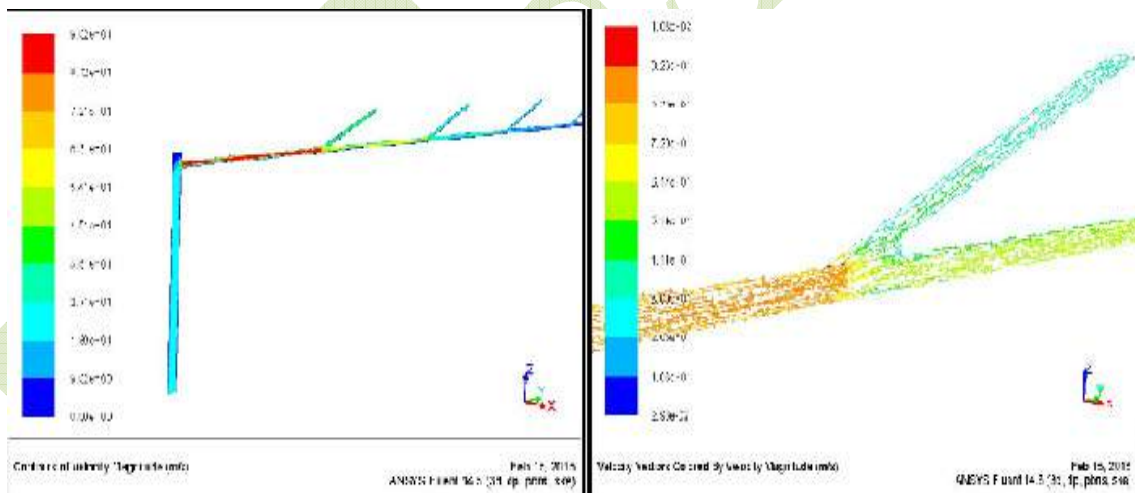
**Velocity Plot:-**

Velocity plot shown in fig. color strip shows the different velocity levels in geometry. At wall o pipe velocity is minimum and at the centre of pipe velocity is maximum Velocity vector shows the flow pattern of fluid. Vortices can be seen using this plot.



**Fig. 7 ANSYS Variant 1**

**Fig. 8 ANSYS Variant 1**



**Fig. 9 ANSYS Variant 2**

**Fig. 10 ANSYS Variant 2**



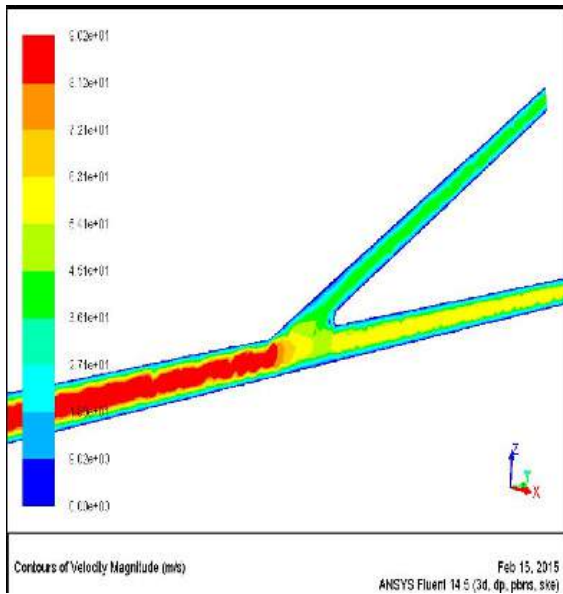


Fig. 11 ANSYS Variant 2

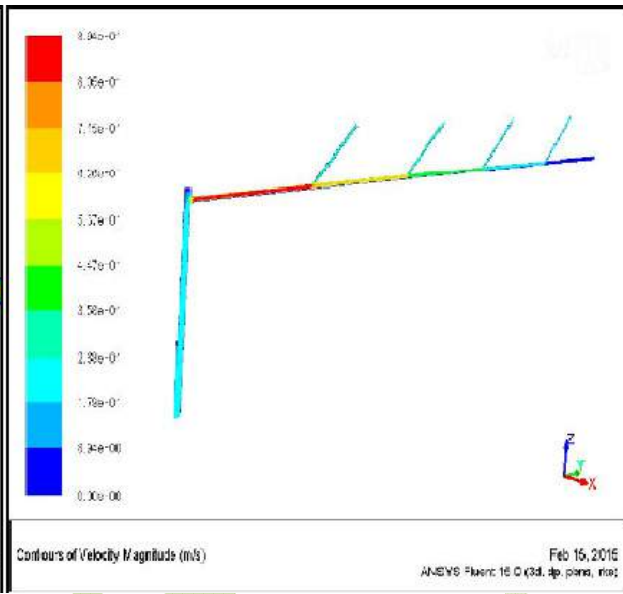


Fig. 12 ANSYS Variant 3

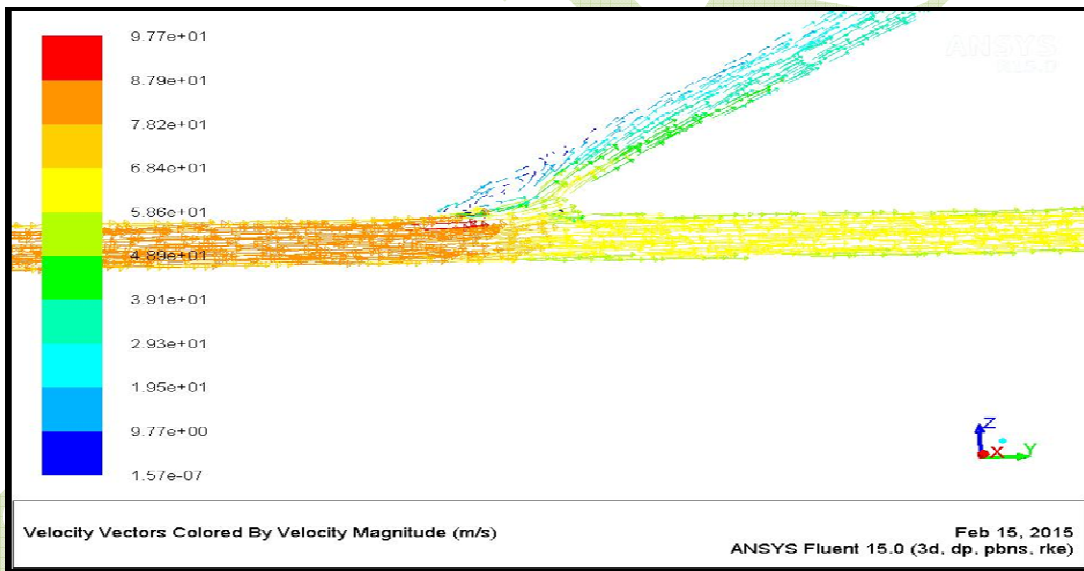
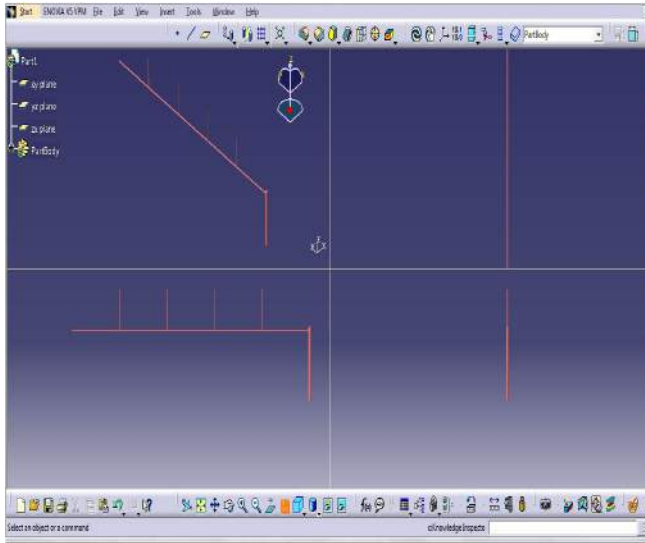


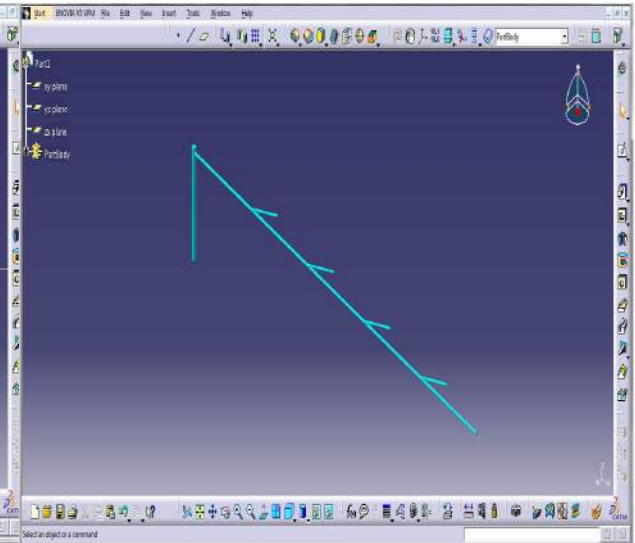
Fig. 13 ANSYS Variant 3

## RESULT AND DISCUSSION

**Discussion:** - In this chapter we will discuss how to design the delivery side. The efficiency of the centrifugal pump can be increased by number of ways such as modifying the geometry of the sump, increasing the diameter of the discharge pump, etc. The following diagram shows a delivery pipe variant 1.

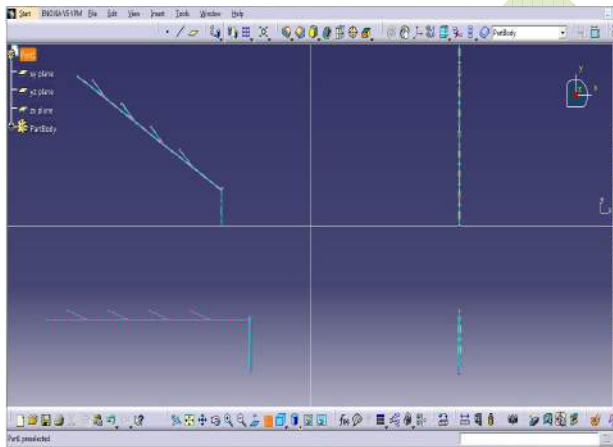


**Fig. 14 Delivery pipe Variant 1**

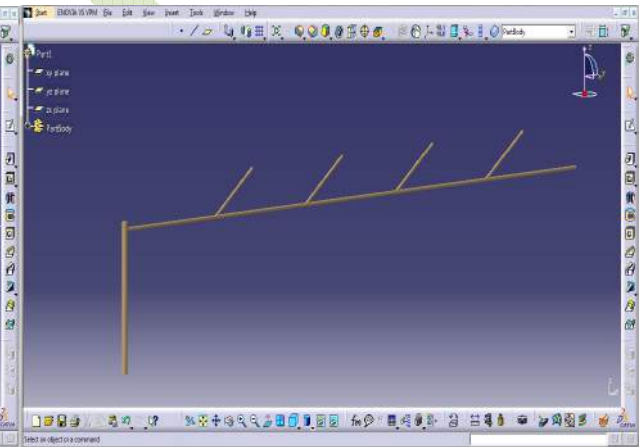


**Fig. 15 Delivery pipe Variant 1**

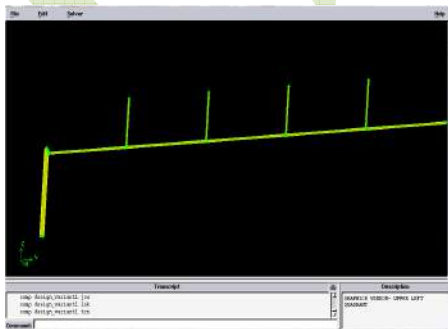
In the similar way we can create all the models in CATIA for analysis. The following Figure shows a model of variants shape of manifold.



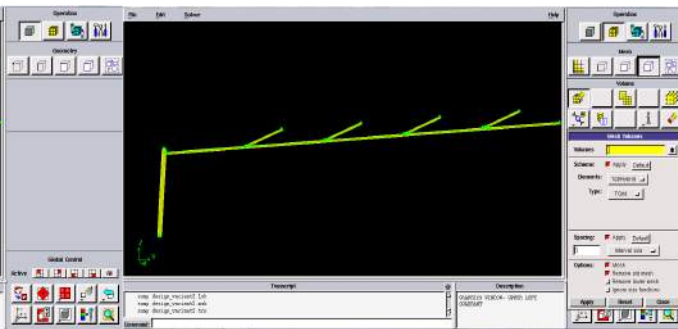
**Fig. 16 Delivery pipe Variant 2**



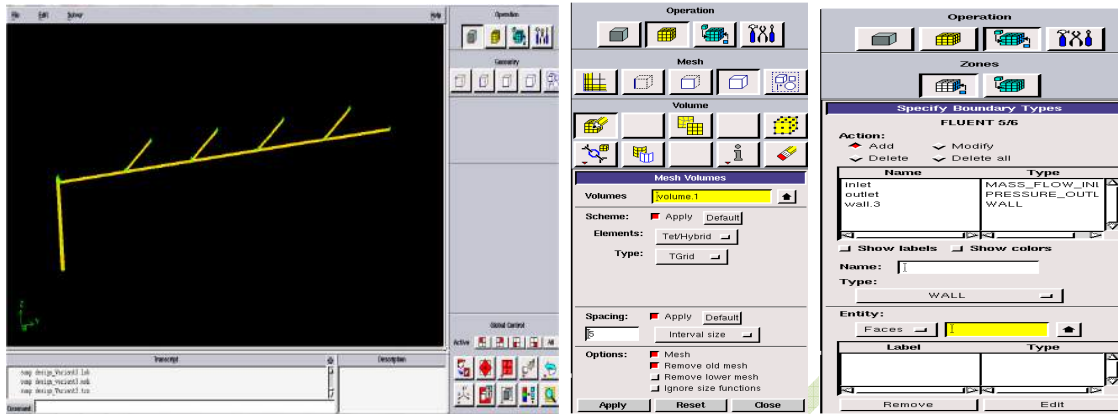
**Fig. 17 Delivery pipe Variant 3**



**Fig. 18 Variant 1**



**Fig. 19 Variant 2**



**Fig. 20 Variant 3**

**Chart 1 Gambit operation**

**Result:-**

The comparison between benchmark and modified model of delivery pipe proposed in our thesis can be very well represented in a tabular format, as shown

Sr. No	Details	Pressure developed (Analytical) in MPa	Remark
1	Variant 1 i.e. Benchmark Geometry	3.161	More vortices developed
2	Variant 3	3.125	Less vortices developed as compared to benchmark geometry
3	Variant 2	1.12	Very less vortices developed as compared to all variants

**Table 1 Comparison between benchmark and modified model**

Comparing the pressure drop in different geometry, Pressure developed in benchmark geometry is more as compared to other variant. When we apply the angle for delivery pipe, fewer vortices generated in 20 deg bend pipe i.e. variant 2. Smooth fluid flow observed in variant 2. Hence less power required for variant 2.

**CONCLUSION**

- Vortices and cavitations' introduce inefficiency on the operation of the centrifugal pump.
- Changing the bend angle of delivery pipe reduces the vortices and cavitations' in pipe.
- The suction head and the delivery head has a bearing on the output of the pump in terms of discharge achieved per KW of pump power.
- The intake pumping stations needs a uniform flow distribution of the sumps in order to ensure the operation of pump units.
- CFD model used to study the effect of various parameters which reduces time as well as cost and hence could become an important tool for optimization of pump sump geometry.
- Redesign of the delivery side of the pump facilitated the flow of water and improves the discharge and consequently the performance of the centrifugal pump.

## REFERENCES

- [1] Abdul Waheed Badar, Reiner Buchholz, Yongsheng Lou and Felix Ziegler; *CFD based analysis of flow distribution in a coaxial vacuum tube solar collector with laminar flow conditions; International Journal of Energy and Environmental Engineering* 2012.
- [2] Chris Smith (Production Assurance Manager at Xodus Group); *A dynamic approach to flow assurance modelling; Technical Paper, Xodus Group.*
- [3] R. Vijayakumar, S.N. Singh, V. Seshadri, (Deptt. of Applied Mechanics, IIT Delhi) *CFD; Analysis for the Design of Optimum Geometry of the Orifices in the PC pipes for ensuring uniform feed rate of Coal through various Coal Burners in a Boiler.*
- [4] Balvinder Singh, Harpreet Singh, Satbir Singh Sehgal; *CFD Analysis of Fluid Flow Parameters within a Y-Shaped Branched Pipe; International Journal of Latest Trends in Engineering and Technology (IJLTET).*
- [5] S. Mokhtari, V.V. Kudriavtsev, M. Danna; *Flow informality and pressure variation in Multi-outlet flow distribution pipes, Advance in analytical, Experimental and computational Technologies in Fluids, Structures, Transient sand Natural Hazards; PVP-Vol.355, AME 1997*

## AUTHORS BIOGRAPHY:



### Mr. S. M. Rajmane

He is having ME from Solapur University. He is Research Scholar for WIT Research Center, Solapur University, and Solapur. He is having more than 10 years teaching experience His area of interest is in Fluid machinery, FEM, Design engineering.



### Dr. S. P. Kallurkar

He is having Phd from NITIE Mumbai. Presently working as Principal in Atharva College of Engineering, Mumbai. He is Research Guide at WIT Research Center, Solapur University, and Solapur. He is having more than 25 years teaching experience.