

# THE IMPACT OF LAND AREA'S SIZE ON THE EFFICIENCY OF THE WORK PLANNING AGGREGATES

KHASANOV I. S.

<sup>1</sup>Candidate of technical science Tashkent institute of irrigation and agricultural mechanizations engineers  
Bukhara branch

QUCHQOROV J. J.

<sup>2</sup>External doctorate student Tashkent institute of irrigation and agricultural mechanizations engineers  
Bukhara branch

KATTAYEV B. S.

<sup>3</sup>Student, Tashkent Institute of Irrigation and Agricultural Mechanization Engineers of Bukhara branch;

SAYLIXANOVA M. K.

<sup>4</sup>Student, Tashkent Institute of Irrigation and Agricultural Mechanization Engineers of Bukhara branch

## ABSTRACT:

In the article impact of land area's size of the efficiency of the planning aggregates in a variety of configurations of land, as well as the authors come to the conclusion that improving the quality of existing planning machines, conducted by improving the design and operation of the technology.

**KEYWORDS:** semi-mounted planner, planning aggregates, a variety of configurations, the performance of machines, the annual output of mechanized work and labor costs.

## INTRODUCTION

In Central and South Asian Republics Kazakhstan plowed field is a small portion of various configurations (contours) with a length of about 100 ... 300 m. As a rule, they are limited mulberry, ditches, trees, etc. VA Tverdohleb [1] notes that in Belarus on average 100 hectares arable lands circuit 31, and the size of excess portions 10 ha only about 42% of the total area. Because of this, a significant part of the change-consuming no cuts turns, heats, moving from area to area. Thus, when the length of the rut 200 m. Similar passages caterpillar tractor plowing reach 32% of the total path traveled by the machine, and with a length not 1500m-Only 9%. Sharply reduced and shift performance of machines - in areas with long rut 151 ... 200 m on average by 20% and the area to 150 m - more than 30% compared to the output of the fields where the length of estrus is 600 ... 1000 m Correspondingly reduced annual output and increases cost of mechanized operations.

According to [1] small fields - one reason why low usage tractor units, since by increasing the amount of fragmentation tractor work stations, referred to 1 ha the cultivated area is reduced (Table 1.1).

Table 1.1

Index	The average length of estrus treated areas are divided into groups, m					
	150	151 ... 200	201 ... 300	301 ... 400	401 ... 600	601 ... 1000
number of farms in Group	110	102	97	111	125	38
Developing tractors on the 1 ha arable land, ga.m.p.	4.5	4.6	5.6	5.8	5.8	6.0

Due no cuts tractor when working on small margins previously worn and consumed more fuel than at large. Thus, when the length to rutting 150 m fuel consumption 1 hallowing 13% higher than when the length of 801 ... 1000 m, besides annual output reduction causes an increase depreciation. Owing to all these reasons,

the unit cost of mechanized operations increased (Table 1.2). The results of correlation analysis [1] gave the following constraint equation:

$$\lg C = 1,06824 - 0.19020 \lg D$$

where C - the cost of implementation 1 ha MP, rub .;

D - the average length of estrus cultivated areas, m.

The theoretical volume of the regression line on the tractor work 1 ha arable execution cost 1 harm the average length of estrus are shown in Figure 1.1 (according to [1]).

Table 1.2

Index	The average length of estrus treated areas are divided into groups, m					
	150	151 ... 200	201 ... 300	301 ... 400	401 ... 600	601 ... 1000
The number of farms in the group	116	90	92	99	94	thirty
Tractors' production 1 ha rm, rub.	4.63	4.61	3.92	3.84	3.51	3.36

VA Tverdohleb as a result of his research makes the following conclusions:

- small outlines of arable land hinders more efficient use of agricultural machinery. Its application least effective on an area of 10 ... 16 m with a length of up to rutting 400 m;

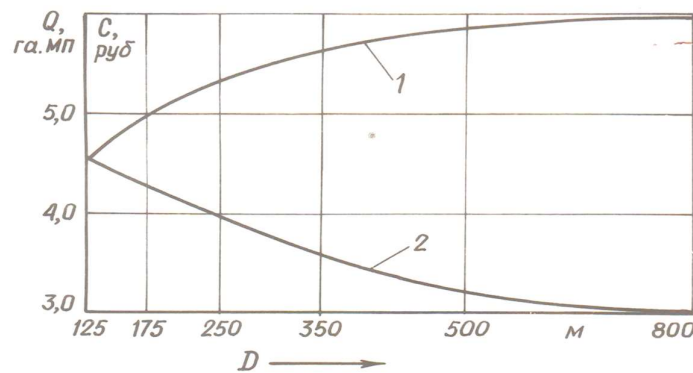

Fig. 1.1. The theoretical volume of the regression line (Q) of mechanized operations for 1 ha arable land (1) and the cost (C) performing 1 harm (2) the length (L) rutting processed portions.

- To eliminate finely contoured conditions for Belarus on the basis of the payback period of reclamation work, it is advisable to increase the areas to be treated in two stages: the first - to estrus length of 400 ... 500 m (10 ... 16 n), the second - up to 800 ... 1000m (over 16 ha).

When MA studies Akhmedzhanova [2] The efficacy of experimental semi-mounted short-base scheduler P-2,8A for various configurations small contoured sections with sides at least 100m showed qualitative performance difficulties with large process repeats (at 1800). In the center irrigated plots small circular motion is very sharp turn unit with overlapping previous races. Scheduler with a tractor at the turn of the corner is close to 90°. In this case, the rear wheels are on-site planner. It promotes preparation of soil. In windy weather on the steep turns of the tractor prevents dust and scheduler tractor driver to follow the direction of motion. Cornering bumps reach 0.3 m. Soil structure deteriorates and there is a strong sputtering.

MA Akhmedzhanov [2] the following conclusions: semi hinged scheduler P-long base with 2,8A11.2 mind the location of the ladle L = 3.5 m from the rear wheels runs satisfactorily at little contoured irrigated plots: on rectangular (50x100 m or more), square (100x100 m and more) as well as a configuration designed with a side length of 100 m or more. He recommends the following scheme of motion planning unit when working

in areas of different configurations: triangular shape of large and small sizes, shapes improper convex quadrilateral large and small size of the comb and a circular shape (Figure 1.2).

Performance and quality of the leveling unit mainly depends on the speed, length of estrus, and properly selecting portion motion scheme.

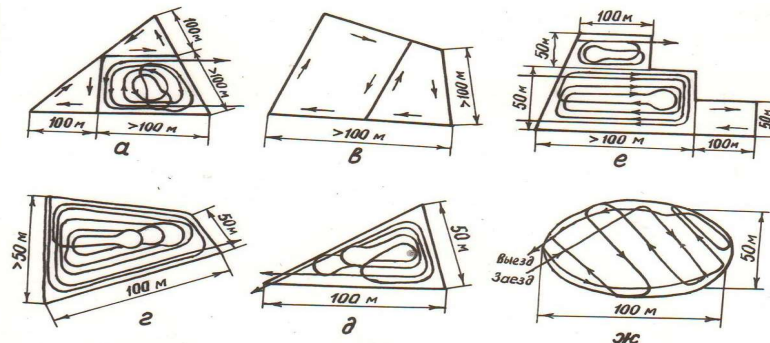

Fig. 1.2. Traffic patterns: A and D - large triangular-shaped small size; and d forms of improper convex quadrilateral large and small sizes; e comb shape; Well - round

These parameters also significantly influence the annual volume of work performed and the change in direct operating costs per hectare, ie, with increasing rutting length reduced costs and increased productivity. Optimal variant is at bout length  $L = 600 \dots 800$  m [3]. This implies that the use is not effective in small areas of the existing long-base scheduler. For such areas, further research should be carried out with a scheduler with a small base and devising the best options for their technology work.

Thus, we come to the following conclusion:

- basically irregularities of up to 30 m and 20cm in height and are caused by soil deformation under the influence of rain, watering pot and machine processing fields, they can flatten long-base schedulers or other units with automatic control of the working member.
- improving the quality of existing planning machines conducted by improving the design and operation of the technology, as well as by automation of the working body. However, the above said is not generally acceptable to little contoured areas
- Application existing scheduler for long-base low-contour portions inefficient because of the loss of time on the turns and reversals decreases productivity, in addition reduced coefficient plan completeness.

## REFERENCES

- 1) Tverdohleb VA Operation of the machine and tractor units on little contoured fields. F-1 "Mechanization and electrification of agriculture." 1969.- №12.-pages 12-13
- 2) Ahmedzhanov MA Research semi-mounted short-base scheduler P-2,8A. F-1. "The mechanization of cotton." -1983.- №1 S.7-9.
- 3) 3..Ahmedzhanov MA Khikmatov PG Khasanov IS Increased productivity long based scheduler little contoured areas. F-1. "The mechanization of cotton." 1992, №1. -WITH. 3-4