

Vehicle Parking Management System

¹Akshay Hetiya, ¹Rahul Chaudhari, ¹Sagar Dhotre, ¹Venugopal Badave,
²Sandipraj Salunkhe

Final Year B. Tech Students, Department of Mechanical Engineering¹
Assistant Professor, Department of Mechanical Engineering²
SVERI's College of Engineering, Pandharpur, Maharashtra, India

Abstract:

With the rapid growth of urbanization and the increasing number of vehicles on the roads, efficient management of vehicle parking has become a critical challenge in many cities. Inefficient parking systems result in various problems, including congestion, environmental pollution, and frustrated drivers. To address these issues, a robust and intelligent Vehicle Parking Management System (VPMS) is proposed.

This paper presentation aims to introduce the concept, design, and implementation of a state-of-the-art VPMS. The system utilizes advanced technologies such as sensor networks, data analytics, and real-time monitoring to optimize the parking process and enhance the overall parking experience for both drivers and parking lot operators.

The VPMS provides several key features to tackle the challenges of urban parking. Firstly, it includes a comprehensive parking space monitoring system that employs sensor networks to detect and track available parking spots in real-time. This information is then communicated to drivers through mobile applications or digital signage, enabling them to locate vacant parking spaces efficiently, reducing search time and traffic congestion.

Additionally, the VPMS incorporates an automated payment system, allowing users to pay for parking digitally via mobile applications or electronic payment methods. This eliminates the need for physical cash transactions, reducing human error and enhancing convenience for users.

Overall, the Vehicle Parking Management System offers an innovative and efficient solution to address the parking challenges faced in urban areas. By leveraging cutting-edge technologies, this system streamlines the parking process, enhances user experience, and contributes to creating smart and sustainable cities. The paper presentation aims to inspire further research and implementation of intelligent parking solutions worldwide.

Keywords: *Vehicle Parking Management System (VPMS), PHP, Xampp Server, Database.*

I. INTRODUCTION

The Vehicle Parking Management System is essential for efficiently managing and organizing parking spaces in various establishments such as commercial complexes, residential areas, educational institutions, and public parking lots. With the increasing number of vehicles on the road, the need for an automated system that simplifies the parking process and enhances security has become paramount. This project focuses on developing a robust Vehicle Parking Management System using PHP, a widely used scripting language for web development. The system aims to streamline the parking management process, providing a user-friendly interface for administrators and users.

The VPMS System will focus on improvements on the following measures :-

- Recognize and validate automobiles at entry and exit points.
- Reduce traffic by enhancing user experience.
- Easy to handle and organise data of vehicles.
- Rectify complications of parking security.

Need of System :

A vehicle parking management system serves several critical needs within the project. Firstly, it addresses the need for efficient utilization of parking spaces in the face of increasing vehicle numbers. By implementing this system, parking space allocation can be optimized, ensuring maximum utilization and reducing congestion. This contributes to a smoother flow of vehicles and a more organized parking environment.

Secondly, the system fulfills the requirement for streamlined parking operations. Traditional manual systems often involve cumbersome processes like manual ticketing, paper records, and human intervention for spot allocation. Automating these processes through a parking management system eliminates manual errors, reduces paperwork, and streamlines parking operations. This leads to improved efficiency and a hassle-free experience for both administrators and users.

Furthermore, the system caters to the need for enhanced user experience. Features such as online vehicle registration, real-time spot availability, and digital payment options make parking more accessible, user-friendly, and time-saving. Users can easily check for available parking spots, register their vehicles conveniently, and make payments without the need for physical tickets or cash transactions.

The implementation of a vehicle parking management system also addresses the need for improved security and surveillance. The system can incorporate advanced security measures such as surveillance cameras, access control, and vehicle identification, ensuring a safer parking environment and deterring unauthorized activities. This provides peace of mind for both vehicle owners and parking facility operators.

Moreover, effective revenue management is a crucial requirement that the system fulfills. By tracking parking duration, calculating charges accurately, automating payment processing, and generating reports, the parking management system ensures transparent revenue management. This reduces revenue leakage and enables parking facility owners to have a clear overview of their financial operations.

The system also fulfills the need for data analysis and insights. By collecting data on parking occupancy, user patterns, and revenue, the system provides valuable insights for future planning and decision-making. Analysis of data trends can help optimize resource allocation, identify peak usage hours, and identify areas for improvement, leading to more informed and effective management practices.

Lastly, the vehicle parking management system contributes to sustainability and environment-friendly measures. It can encourage initiatives such as carpooling, electric vehicle charging stations, and incentives for eco-friendly transportation. These measures align with environmental goals, promote sustainable practices, and contribute to the reduction of carbon emissions.

In summary, the vehicle parking management system effectively addresses needs such as efficient parking space utilization, streamlined operations, enhanced user experience, improved security, revenue management, data analysis, and sustainability. By fulfilling these needs, the system offers significant benefits and value to the project, contributing to a more efficient, organized, and user-friendly parking environment.

1.3 Software Aim :

The aim of the software is to provide a comprehensive vehicle parking management solution that automates and streamlines all aspects of the parking process. It aims to optimize parking space utilization, ensuring maximum efficiency and reducing congestion. The software aims to enhance the user experience by offering convenient features such as online vehicle registration, real-time spot availability, and digital payment options. It also focuses on improving security and surveillance measures to create a safer parking environment. Additionally, the software aims to facilitate effective revenue management by accurately tracking parking duration, calculating charges, automating payment processing, and generating detailed reports. Overall, the software aims to provide a centralized and efficient system that offers seamless parking operations, enhanced user satisfaction, and improved financial management for parking facility owners.

II. LITERATURE SURVEY

Existing System:

The current system for vehicle parking management relies on manual processes and paper-based documentation. The traditional approach involves manual ticketing, physical record-keeping, and human intervention for spot allocation. This system is prone to errors, inefficiencies, and delays. It lacks real-time information on parking spot availability, resulting in frustration and time wastage for users. Revenue management is also challenging, with difficulties in accurate tracking, payment collection, and generating comprehensive reports. Additionally, the absence of advanced security measures increases the risk of unauthorized activities and compromises overall safety. The vehicle parking management system (VPMS) aims to replace this outdated system by automating processes, offering online registration and payment options, providing real-time spot availability updates, enhancing security measures, and enabling efficient revenue management. The VPMS will revolutionize the parking experience by streamlining operations, improving user convenience, ensuring accurate data management, and promoting a safer and more efficient parking environment.

The disadvantages of existing Parking Management can be listed as under:

1. Manual Processes:

The reliance on manual processes, such as manual ticketing and record-keeping, increases the chances of errors, inconsistencies, and delays. It requires human intervention for tasks that could be automated, leading to inefficiencies and potential mistakes.

2. Lack of Real-Time Information:

The current system often lacks real-time information about parking spot availability. Users may have to physically check each spot or rely on outdated information, leading to frustration and wasted time when searching for parking.

3. Inefficient Space Utilization:

Without a centralized system to manage parking space allocation, there is a higher probability of inefficient utilization. Certain spots may remain vacant while others are overcrowded, causing congestion and inconvenience for users.

Proposed System:

The proposed Vehicle Parking Management System (VPMS) aims to revolutionize the current parking system by introducing an advanced, automated solution. The VPMS will streamline parking operations, offering features such as online vehicle registration, real-time spot availability updates, and digital payment options, improving user convenience and reducing waiting times. It will optimize parking space utilization, ensuring maximum efficiency and reducing congestion. The system will incorporate advanced security measures, including surveillance cameras, access control, and vehicle identification, to enhance safety and deter unauthorized activities. With comprehensive reporting and analytics capabilities, the VPMS will provide valuable insights for better resource allocation and decision-making. Overall, the proposed VPMS promises to provide a seamless, user-friendly experience, efficient revenue management, and secure parking environment.

III. SYSTEM SPECIFICATION

User Interface:

- The system will have a user-friendly web-based interface accessible through standard web browsers.
- The interface will be designed using HTML, CSS, and Bootstrap framework to ensure responsiveness and visual appeal.
- It will include intuitive navigation, clear forms for data input, and informative feedback messages for user interactions.

Authentication and Access Control:

- The VPMS will provide secure user authentication mechanisms to ensure authorized access for administrators and users.
- Different user roles and permissions will be implemented to control access to various system functionalities and data.

Vehicle Registration and Management:

- Users will be able to register their vehicles by providing necessary details such as vehicle type, registration number, and owner information.
- The system will validate and store the registered vehicle data for future reference and management.

Parking Spot Management:

- The VPMS will maintain a database of parking spots available in the parking facility.
- It will track the occupancy status of each spot, indicating whether it is vacant or occupied.
- Real-time updates on spot availability will be displayed to users, allowing them to check and reserve available spots.

Payment Processing:

- The system will facilitate digital payment options, including credit/debit card payments or mobile wallet integration.
- It will calculate parking fees based on factors such as duration and vehicle type.
- Secure payment gateways will be integrated to ensure safe and encrypted transactions.

Reporting and Analytics:

- The VPMS will generate comprehensive reports and analytics regarding parking occupancy, revenue, and user patterns.
- It will offer graphical representations and data visualization to aid in decision-making and planning.

IV. Working

Vehicle Parking Management System (VPMS) involves a series of interconnected processes and interactions between users, administrators, and the underlying system components. Upon accessing the system, users can register their vehicles by providing the necessary information such as vehicle type, registration number, and owner details. The system validates and stores this data for future reference.

To find an available parking spot, users can check the real-time spot availability displayed on the system interface. Once a spot is selected, the user can reserve it for a specific duration. The system updates the spot status as "occupied" and generates a unique reservation ID for reference.

During the parking duration, the system keeps track of the occupied spots and monitors the entry and exit times of vehicles. Payment processing is handled digitally, allowing users to make payments using secure online payment gateways integrated into the system. The system calculates the parking fee based on factors such as duration and vehicle type.

For administrators, the system provides a dedicated interface to manage parking spots, users, and generate reports. Administrators can monitor the overall parking occupancy, add or remove parking spots as required, and generate comprehensive reports on revenue, occupancy trends, and user statistics.

Throughout the entire working process, the VPMS incorporates security measures such as surveillance cameras, access control systems, and vehicle identification. These measures ensure the safety and integrity of the parking facility.

The working of the VPMS is designed to be user-friendly, efficient, and secure, providing a seamless experience for both users and administrators. By automating and streamlining parking operations, the system improves efficiency, reduces errors, and enhances the overall parking management process.

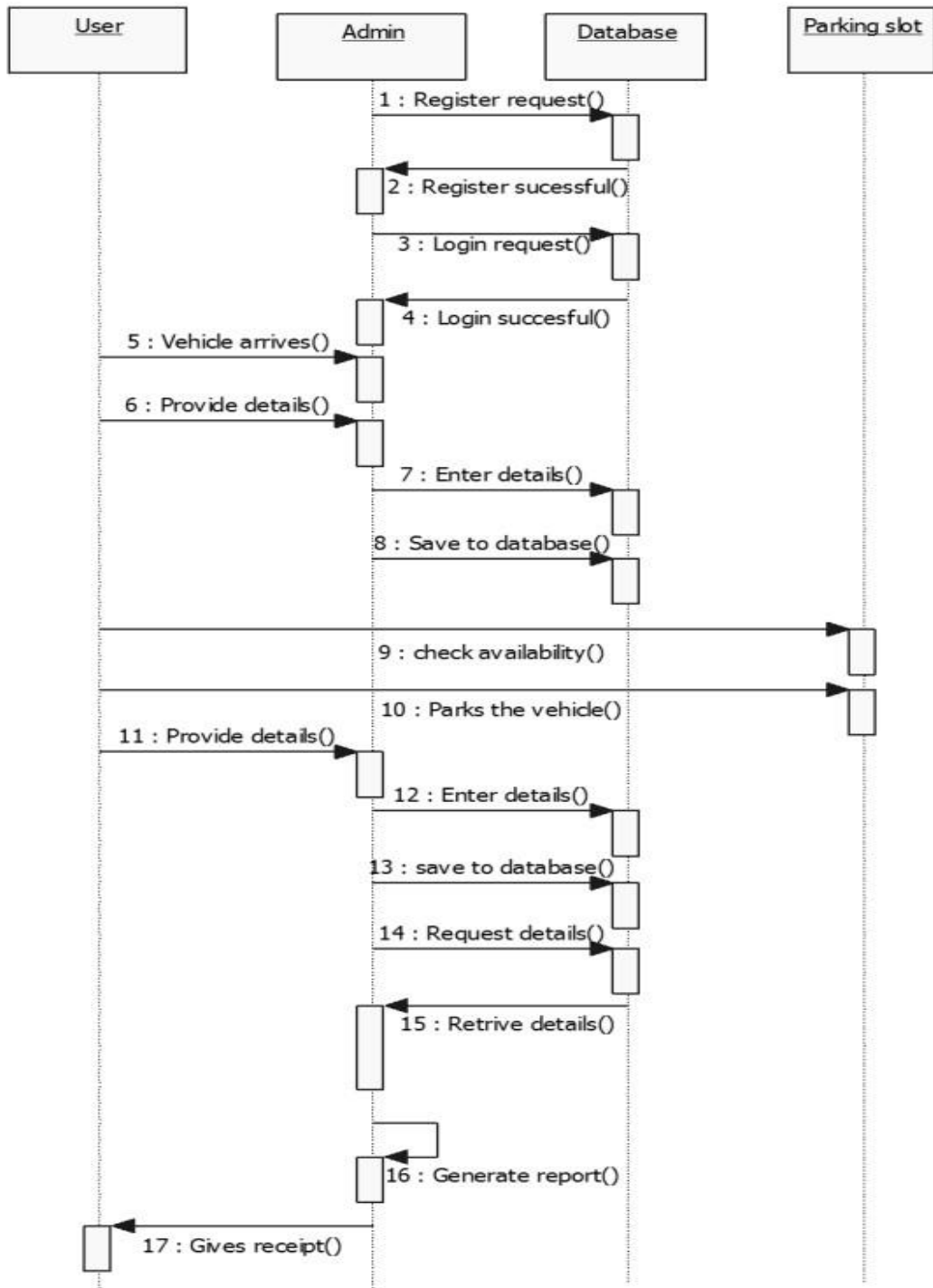

Sequence Diagram

V. Final Result:

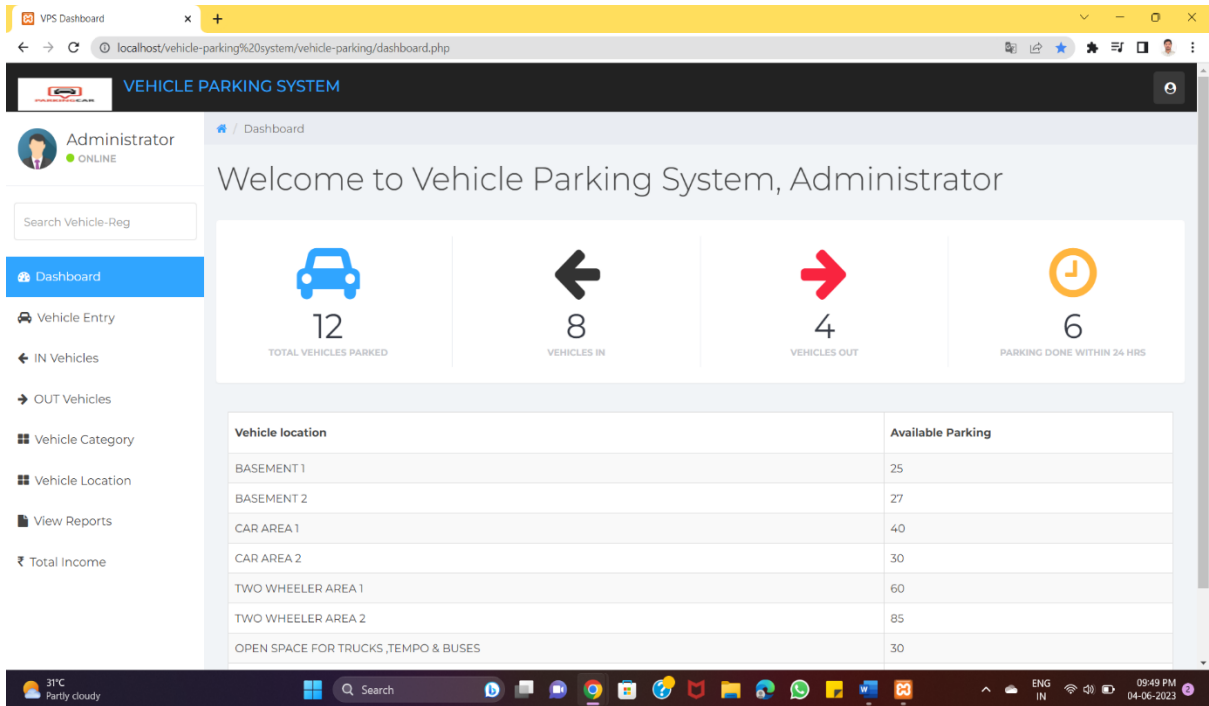

Figure : Output

It displays the final result of software interface, it includes Vehicles Parked Details, Parking Space Availability, Menu for various options like vehicle entry & exit.

VI. Conclusion

The proposed Vehicle Parking Management System (VPMS) offers a comprehensive solution to address the challenges and limitations of the current parking management system. By leveraging advanced technologies, automation, and user-friendly interfaces, the VPMS aims to revolutionize the parking experience for both users and administrators.

The VPMS optimizes parking space utilization, reduces congestion, and provides real-time spot availability updates to users. Through online registration and digital payment options, it enhances user convenience, eliminates manual errors, and reduces waiting times. The integration of advanced security measures ensures a safer parking environment, while comprehensive reporting and analytics capabilities enable data-driven decision-making for administrators.

Overall, the VPMS aims to streamline parking operations, enhance user satisfaction, improve security, and provide valuable insights for better resource allocation and planning. By replacing the limitations of the current system, the VPMS offers a modern, efficient, and user-centric approach to vehicle parking management, meeting the evolving needs of parking facilities in the digital age.

VII. Future Scope

The scope of the project include that what all future enhancements can be done in this system to make it more feasible to use :

- 1.** Integration with emerging technologies such as IoT, AI, or ML for automated processes, intelligent parking space allocation, and predictive analytics.
- 2.** Explore mobile application integration to provide enhanced convenience for vehicle owners, including features like real-time parking space availability, reservation, and mobile payment.
- 3.** Scalability considerations to accommodate larger parking facilities or multiple locations, ensuring the system can handle increased demand and complexity.
- 4.** Explore integration with smart payment systems, such as digital wallets or contactless payment options like UPI, to provide seamless and convenient payment experiences for vehicle owners.

VIII. References

- 1] Mohsin, M., Jan, M. A., Nawaz, M., & Nawaz, R. (2021). "Design and Implementation of a Web-based Vehicle Parking Management System." *International Journal of Advanced Computer Science and Applications*, 12(5), 124-131.
- 2] Lerdorf, R., Tatroe, K., & MacIntyre, P. (2017). "Programming PHP: Creating Dynamic Web Pages." O'Reilly Media.
- 3] Welling, L., & Thomson, L. (2016). "PHP and MySQL Web Development."
" Addison-Wesley Professional.
- 4] Williams, B., Lane, C., & Welling, L. (2015). "Professional PHP Programming." Wrox.
- 5] Powers, S. (2014). "Learning PHP, MySQL, JavaScript, CSS & HTML5: A Step-by-Step Guide to Creating Dynamic Websites." O'Reilly Media.