

## **ARDUINO BASED OBJECT SORTING**

MR. UMESH A. CHATTE

Assistant Professor, Department of Electrical Engineering, SKNSCOE Pandharpur, India  
umesh.chatte@sknscoe.ac.in

MR. UTKARSH KADAM,

Department of Electrical Engineering, SKNSCOE Pandharpur, India  
utkarshkadam309@gmail.com,

MR. VIKRAM KHUPASE,

Department of Electrical Engineering, SKNSCOE Pandharpur, India  
vikramkhupase@gmail.com

MR. SANKET MANE,

Department of Electrical Engineering, SKNSCOE Pandharpur, India  
sanketmane1234@gmail.com

MS. POOJA KHARAT

Department of Electrical Engineering, SKNSCOE Pandharpur, India,  
poojakharat023@gmail.com

### **ABSTRACT**

Now a day's industrial area requires demand for automation. Due to automation human efforts are going on decreasing since last decade. The object sorting based on colour is difficult task in recent days. In industry there is rapidly increasing demands for automation. The sorting of objects based on colour is very difficult task. This project gives us an idea about automatic colour sorting. Here we are designing and implementing an efficient colour sorting using colour sensor TCS3200 based on Arduino UNO. This project gives high accuracy and performance. Easy to operate and construct which reduces human errors. Existing sorting method uses a set of inductive, capacitive and optical sensors to differentiate object colour.

**KEYWORDS:** Arduino, Colour Sensor, Servo Motor, DC Motor, Conveyor Belt etc.

### **I. INTRODUCTION**

The ability to differentiate colours are essential for human's life as it gives us the awareness about the changes in surrounding through our vision. Moreover, by exploiting the ability of colour capture, intelligent machine gains the function to differentiate, sort and organize. The project consists of sensors that detect object colour after that sends the information to Arduino Uno which in turn adjusts the DC motor which is located just below the object slider to move it left and right also remaining carries as it is straight. Based upon the colour detected and motor will move clockwise or anticlockwise depend on object of colour. The stations are in red, green and blue respectively. After every object placement, the slide will go back to its default angle position, awaiting the next colour object.

Throughout the years, many people tried to use various ways to programme and create intelligence robot in various ways to have respective function or achieving goals. Some of the claims made have contributed directly or indirectly to the project. This project is developed with the purpose of minimizing the cost, optimizing the productivity and reducing human mistakes.

### **II. METHODOLOGY**

In that project object is sorted by colour. Object moves through the conveyor belt and sensed by the colour sensor. For system, the simplest way they can use to detect colours by uses the filters of three main colours, which are red, green and blue and compared the value on the light reflected on it. The value taken will then send signal to Arduino which analyse which colour is the object. The colour sorting system code is programmed using Arduino software. Programming code is researched and written in order for the colour

sorting system to carry out recognition and sorting mechanisms. The connection is done by connecting wires to connect up Arduino Uno which act as microcontroller, servo as well as colour sensor. The servo motor then slides the ball left and right at different angle to different location. The hardware is consists of colour sensing connection, colour recognising connection and system body. The software is done by using Arduino UNO.

### III. SYSTEM DESCRIPTION

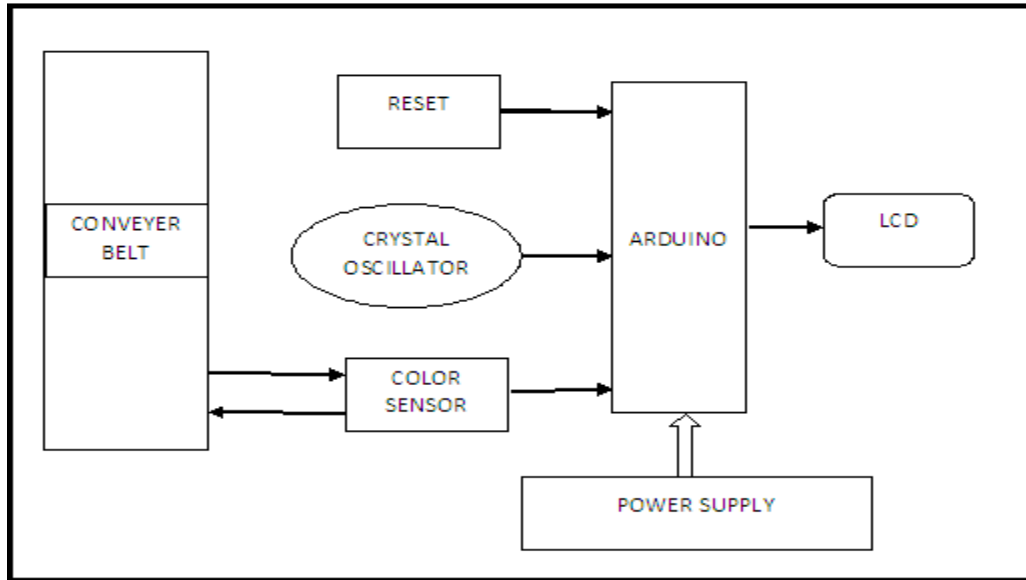
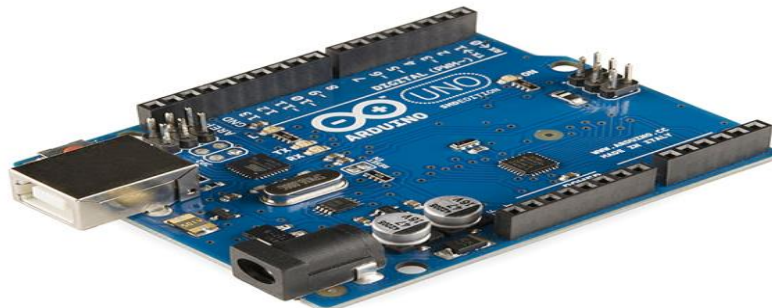

Fig1. Block Diagram

#### ARDUINO

An Arduino board consists of an Atmel 8-bit AVR microcontroller with integral segments that stimulate programming and joining into different circuits. A critical part in an Arduino is its standard connectors, which gives a chance to associate the CPU board to an assortment of compatible extra modules known as shields. Official Arduino uses the mega AVR arrangement of chips, particularly the ATmega8, ATmega168, ATmega328, ATmega1280, and ATmega2560. Arduino is an easy to use hardware and software which is based on open source electronic platform. Arduino boards are useful to publishing something online, turning on LED, a figure on button, read input-light on a sensor. You can tell your board what to do by sending a set of instructions to the microcontroller on the board. To do that things so you can use the Arduino programming language (based on Wiring), and the Arduino Software (IDE), based on Processing.



Photograph no.2: UNO Board

## ARDUINO SPECIFICATIONS

- € Microcontroller -ATmega328 .
- € Operating Voltage 5V Input Voltage (recommended) 7-12V .
- € Input Voltage 6-20V .
- € Digital input output Pins 14 (in which 6 provide PWM output)
- € 6 DC Analog Input Pins 6
- € Current per Input output Pin 40 mA DC Current for 3.3V Pin 50 Ma.
- € Flash Memory 32 KB (ATmega328).

## LCD

In this project LCD is used for display of result. The size of display is 16 characters x 2 lines and in that characters 5x8 dots. The display data RAM is 80 characters and character generate ROM 192. LCDs are also used in a more small devices such as a digital cameras, watches, calculators, mobile telephones and also smartphones etc.

## COLOUR SENSOR-

This present reality hues are comprehended by the Arduino by interfacing the shading sensor with our Arduino. The shading sensor utilizes a TCS3200 at its heart and they can be digitally interfaced with the Arduino and the shading that is before the sensor is been recognized by the Arduino by a reasonable calculation that is used for distinguishing the color. Essentially hues are said that it frames from three guardian parts as "RBG" feeling abnormal. The measure of the parts that are stirred up to frame any unmistakable shading has this hue.

## RESULT:

The object are sorted out with respect to colour such as red, green and blue, also sorted objects are displayed on LCD. The use of automation in colour determination, sorting objects process becomes simple due to which counting and sorting process reduces manual efforts, which leads to improving accuracy as well as save money and time.

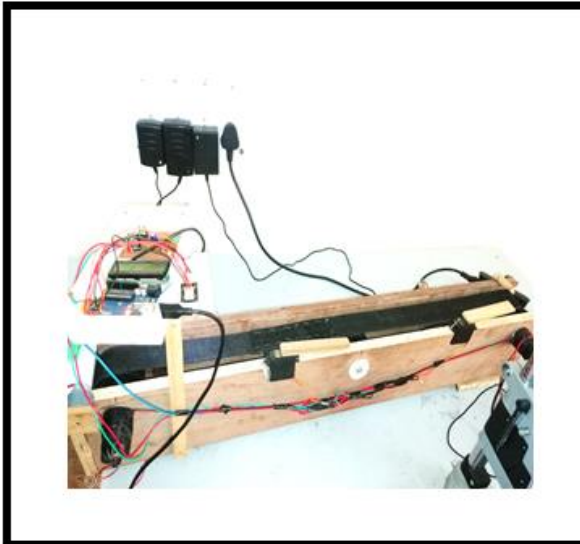

Photograph 1

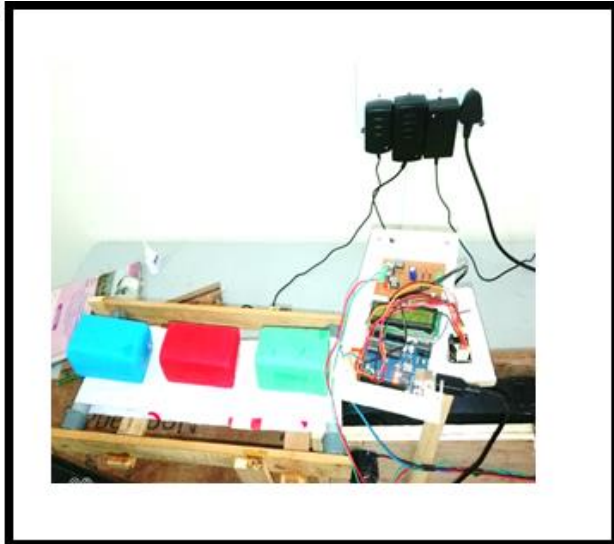

Photograph 2

## CONCLUSION

Now a day's more competition occurs in industrial manufacturing, the management of first stage to the last stage of manufacturing is of very important and in industries the sorting of object is large process. So this object sorting project is an excellent one because of its working and simplicity. By using the idea of this project in an industry can be sort easily sort the required product according to colour.

## REFERENCE

- I. LIM JIE SHEN, IRDA HASSAN, “DESIGN AND DEVELOPMENT OF COLOUR SORTING ROBOT” Journal of Engineering Science and Technology EURECA, Special Issue January (2015) 71 – 81
- II. Snehal Shirgave 1 , Aishwrya Salunkhe2 , Khadija Shirgave3 , S. Y. Upadhye4” Color Sorting Robot” International Journal of Advanced Research in Computer and Communication Engineering ISO 3297:2007 Certified Vol. 6, Issue 3, March 2017
- III. Tushar G. Gaikar, Soham N. Zadokar, Rajendra S. Bhandari, Sagar S. Patil “Object Sorting using Color Sensor and Arduino” International Journal on Recent and Innovation Trends in sComputing and Communication. Volume: 4 Issue: 4, | April 2016.