

SPEED CONTROL OF UNIVERSAL MOTOR USING UNIVERSAL BRIDGE

MR. P. P. KULKARNI

Electrical Department, Sanjeevan Engineering Institute and Technology, Panhala, Kolhapur. India.

BARALE RENU

Electrical Department, Sanjeevan Engineering Institute and Technology, Panhala, Kolhapur. India.

POTE TEJASHREE

Electrical Department, Sanjeevan Engineering Institute and Technology, Panhala, Kolhapur. India.

SUTAR KOMAL

Electrical Department, Sanjeevan Engineering Institute and Technology, Panhala, Kolhapur. India.

POWAR VAISHALI

Electrical Department, Sanjeevan Engineering Institute and Technology, Panhala, Kolhapur. India.

ABSTRACT

Speed control of AC and DC motor is carried out by using universal bridge drive. This universal Bridge which consist combination of IGBT & MOSFET and Diodes by changing the gate pulses. This universal Bridge is controlled by V/F control method. This method is used for single phase AC and DC motor control with small modification in hardware and software using Simulink. Power circuit includes inverter which connected to PWM generator. There are many industrial and domestic applications where speed variation is required, many speed control techniques are used like rheostat control, variable voltage control, v/f control. The simulation is carried out in MATLAB. The characteristics of motors can be studied from waveform obtained by simulation.

INTRODUCTION

In electrical drives we have various speed control methods to control speed of 1 ϕ and 3 ϕ AC and DC motors. For speed controlling of motors we use separate bridge circuits such as rectifier and inverter circuit which include power electronic devices. The rectifier circuit controls speed of AC motor and inverter circuit controls speed of DC motor. To overcome this problem we have created a single bridge which acts as rectifier as well as inverter and controls speed of AC as well as DC motor. This single bridge circuit includes combination of MOSFET's and SCR's, where MOSFET's are voltage controlling devices hence this are used to form inverter bridge circuit and SCR's are current controlling devices hence this are used to form rectifier bridge circuit.

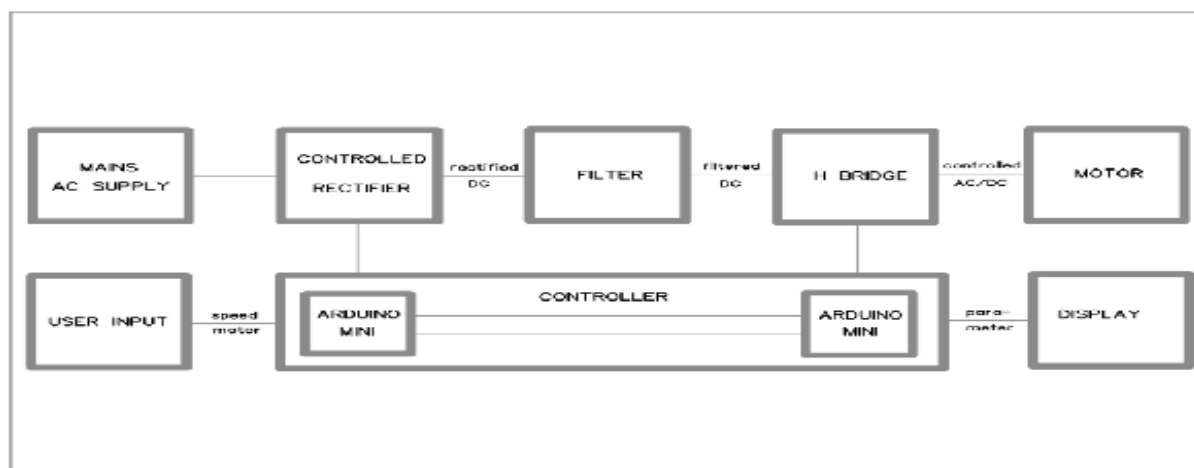

Fig.1. Block Diagram

I. HARDWARE IMPLEMENTATION

A. POWER SUPPLY CIRCUIT

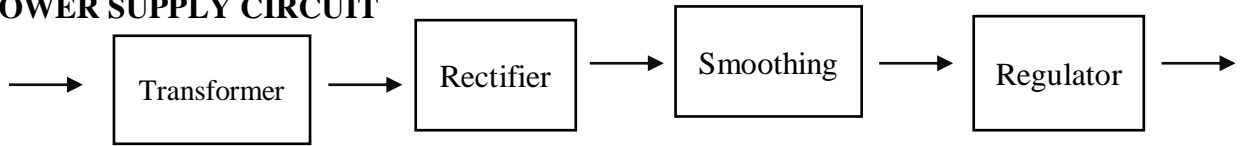

Fig.2. Block Diagram of power supply

The power supply circuit consists of step down transformer 230/12V which is passed through single phase bridge rectifier. The rectifier converts the alternating current (AC to DC) and capacitor filters are used for smoothing out the DC. The above fig. shows the block diagram of power supply circuit.

B. CONTROL CIRCUIT

The control circuit consists of microcontroller-Arduino Pro Mini w/ATMega328, MOSFET's and SCR's and circuit is controlled by gate signal. The microcontroller circuit requires +5V DC supply. The 12 V from the 230/12V step down transformer is rectified and a constant voltage of 5V DC is obtained with the help of voltage regulator. The switching schemes to the metal oxide semiconductor field effect transistor (MOSFET) are generated by microcontroller. This microchip is controller circuit that is used to generate the modulated and carrier signal for the inverter. For generation of modulating output for inverter the zero crossing detector (ZCD). The schematic of the control circuit is,

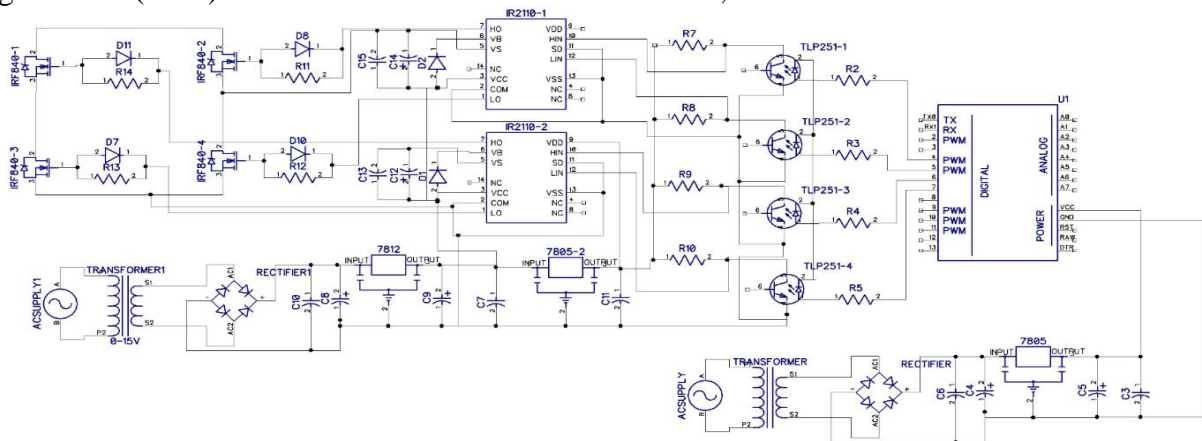

Fig.3. MOSFET Driver

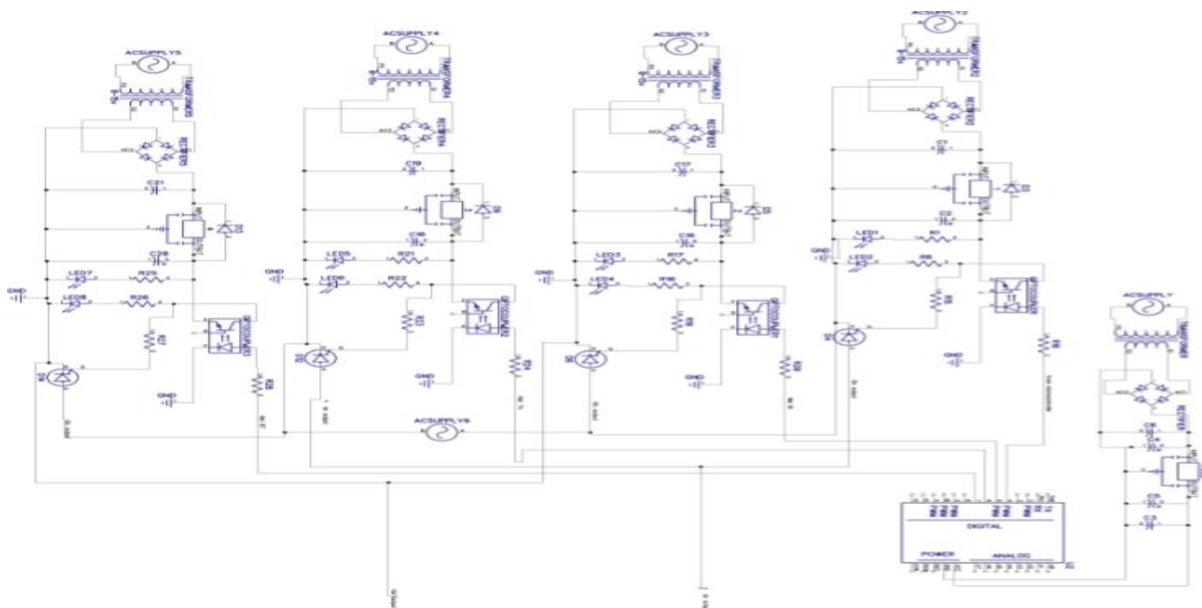

Fig.4. SCR Driver

C. DRIVER CIRCUIT

The driver circuit consists of universal bridge which consists combination of MOSFET's, SCR's driving the gate signal. The driver consists of optocoupler-4N33 which isolates electrical signals. The driver also consists of IC-IR211D which acts as gate drive. The below fig, shows schematic of driver circuit,

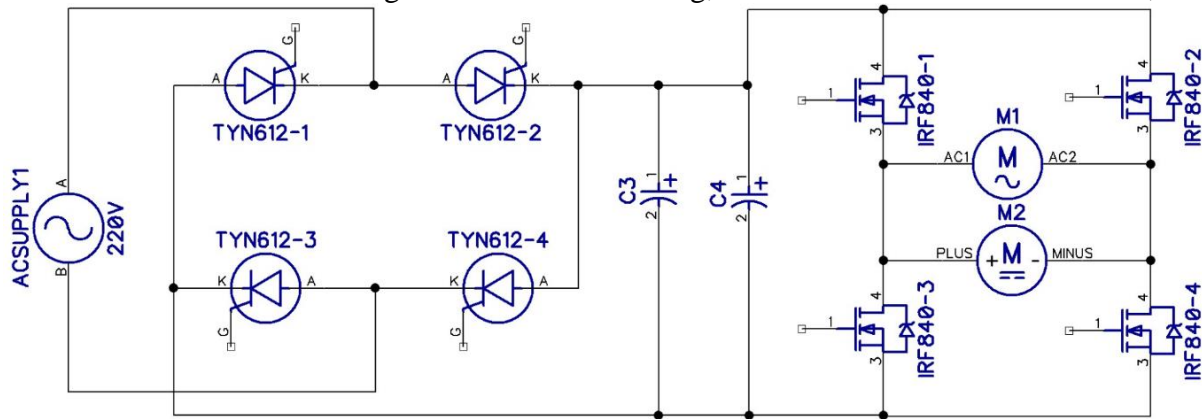

Fig.5. Diver Circuit

D. MICROCONTROLLER (Arduinio Pro Mini ATmega w/328)

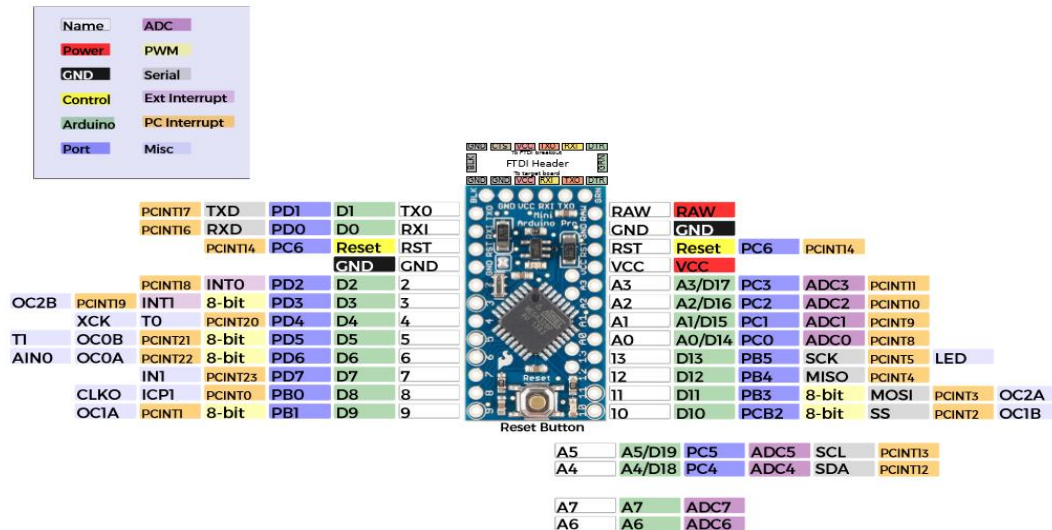

Fig.6 Pin diagram of ArduinioProMini

The Arduino Pro is microcontroller board based on the ATmega328P. The Pro comes in 5V/16MHz. It has 14 digital input/output pins, 6 analog inputs, a battery power jack, a power switch, a reset button, and holes for mounting a power jack, an ICSP header, and pin headers. A six pin header can be connected to an FIDI cable or Sparkfun breakout to provide USB power and communication to the board.

The Arduino Pro is intended for semi-permanent installation in objects or exhibitions. The board comes without pre-mounted headers, allowing the use of various types of connectors or direct soldering of wires. The pin layout is compatible with Arduino shields.

II. RESULT

The following tests was conducted in laboratory.

1. DC motor load was connected at the output of inverter and speed was varied by using variable pot. Input voltage 230V AC, Output Voltage 230V, DC motor rating:-230V, 11A, 1500 RPM, 3HP.

The variation of speed with armature current is shown in bellow graph:

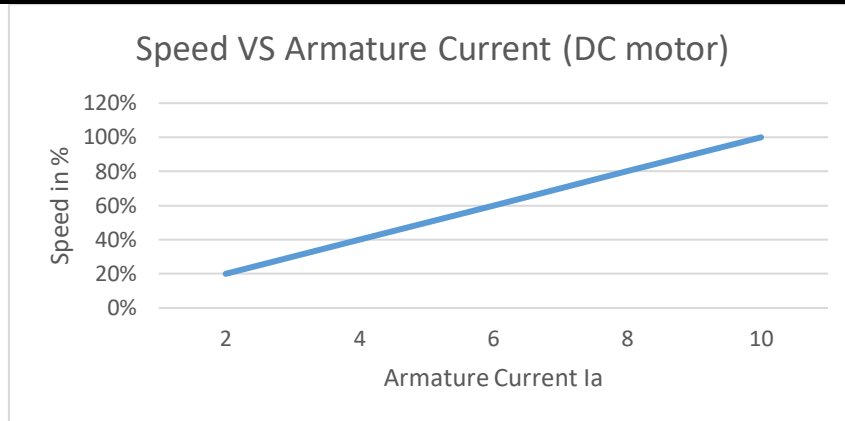

Fig.7 Waveform across load at different values of armature current.

- A Fan load was connected at the output of inverter and speed was varied by using variable pot.
Input voltage 230V AC,
Output voltage 230V,
Induction motor rating:-230V, 1250RPM, 1A, 55W.

The variation of speed with current is shown in bellow graph:

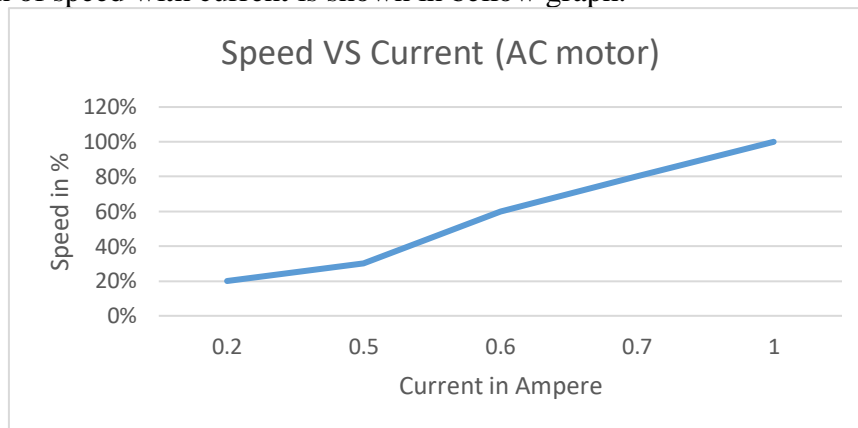

Fig.7 Waveform across load at different values of current

III. CONCLUSION

This paper presents variable frequency drive to control the speed of 1 ϕ and 3 ϕ AC and DC motor. The main aim this project is to create a universal control board through which controlled a single or three phase AC and DC motor, with slight software and hardware modification. This universal board can hence used for different kinds of laboratory applications. The designed system was successfully fabricated and tested in the laboratory.

AKNOWLEDGEMENT

The authors are truly grateful to Mr.P.P. Kulkarni and Mr N.S. Jadhav sir for their valuable suggestions in reviewing the manuscript.

REFERENCES

JOURNAL PAPERS

- (1) Ranjit Kumar Bindal¹,Amandeep Kaur².Speed Control Of Induction Motor Drive Using Universal Bridge, International Journal for Research in applied Science & Engineering Technology.

BOOKS

- (1) M. H. Rashid, Power electronics (circuits, devices and applications).

THESES

- I. Ismail, S.Taib, A.R Mohdsaad, M. Isa and I, Daut,”Development of control circuit for single phase inverter using Atmel Microcontroller,”
- II. Thida Win, Nang Sabai, and Hnin Nandar Maung, “Analysis of variable frequency three phase induction motor drive”.
- III. Mohd Fakhizan bin Ramie, Mohammad Fadhil Pesol, and Khaisul Nisak Md has an, “PWM technique to control speed of induction motor using MATLAB”.
- IV. Rodolfo Enchilada, Sergio Horta, Marco Oliver, has, “A three phase motor drive using IGBT/MOSFET and constant V/F speed control with slip regulation”.3