

## A REVIEW OF DECOUPLING OF FLUCTUATING POWER TECHNIQUES IN SINGLE-PHASE SYSTEMS THROUGH A SYMMETRICAL HALF-BRIDGE CIRCUIT

[PAPER ID: ICITER- D 202]

MR. MALVATKAR SUNIL DASHRATH

Department of Electrical Engineering, Mss's College Of Engineering & Technology Nagewadi Jalna-431203, Maharashtra.

MR. K.V. RAMMOHAN

Assistant Professor, Department: Electrical Engineering, College Name: Mss's College Of Engineering & Technology, Nagewadi Jalna-431203, Maharashtra.

### ABSTRACT:

Single phase AC to DC converters or DC to AC converters possesses extremely wide application in industrial and residential power supply equipments or in case of conversion systems. Some of the major applications are power factor correction equipments in case of consumer power supplier, mobile chargers, and charging power for charging hybrid vehicles or electrical vehicles. And it also included grid connected power photo voltaic cells of less than 5KW. A well known problem and deeply addressed with such systems is that their ac-side instantaneous power contains a ripples that changes at twice the power frequency. This fluctuating power may affect the system performance because it contains potential cause which may distort the input current of PFCs, and it may also overheat the batteries and it also results in decreased maximum power point tracking (MPPT) efficiency of PV systems. A very straight forward way for mitigating its negative impact is by using bulky electrolytic capacitors in the DC link so that they can act as filters to AC side DC offset. However those electrolytic capacitors are better known for equivalent series resistance (ESR) and low ripple current capability, and their lifetime is also relatively shorter (may be for several thousand hours) particularly when stressed with the nominal voltage.

**KEYWORDS:** Symmetrical half-bridge circuit, Grid connected systems, Power converters etc.

### INTRODUCTION:

In today world, some active power decoupling methods had been proposed and implemented to cope with this problem and many times the fundamental principle behind them is accomplished by introducing an extra active circuit in the system, so that the ripple power can be shifted from dc link and associated components which give an advantage of increased life e.g., inductors and film capacitors, in a more efficient and effective way. Fig. 1(a) shows an active method which uses an inductor for active ripple energy storage; in this

case the inductor current is controlled by using the sinusoidal current, which is accomplished through the modulation of the added third switching leg. A similar type of concept is shown in fig 1 (a), where the last switch of the third leg is replaced with a diode for saving one active component, and in this case, the inductor current can be controlled as rectified sinusoidal in order to cancel those ac-side ripple power. Even though inductors are robust and reliable, they are mostly used where applications of low power density and power losses in a great demand, when inductor is used as energy storage elements for power frequency components, and therefore, the performance improvement could be very limited. If the inductor is interchanged with a film capacitor and the ripple power can then be compensated by controlling the voltage of the film capacitor to be rectified sinusoidal as shown in Fig. 1(b). Moreover these waveforms contain the higher-order harmonics which will be difficult for tracking and controlling in highly under damped second-order system. By using exactly the same circuit configuration. The research proposed by wang et.al. A technique where dc offset voltage is introduced near to capacitor in connection to the capacitor for the purpose of reduction in lower order harmonics and it may also facilitate the closed loop design of the controller. Nevertheless, since the capacitor voltage does never goes down to zero, it will not get fully discharged, which implies that the film capacitor is not fully utilized. The similar type of concept was used in capacitive ripple power decoupling had been observed in few cited papers. More modern techniques proposed active power decoupling method are shown in and its circuit diagram is shown in Fig. 1(c). The introduced half-bridge, together with one leg of the full-bridge rectifier, it forms a full-bridge circuit, and in this case, the voltage of the film capacitor can be controlled to be sinusoidal and it resolves all the difficulties mentioned previously. Even though being effective in ripple power compensation, this topology is not applicable in some cases, e.g., power factor corrections and unfolding bridge-based inverters, because of power flow is unidirectional.

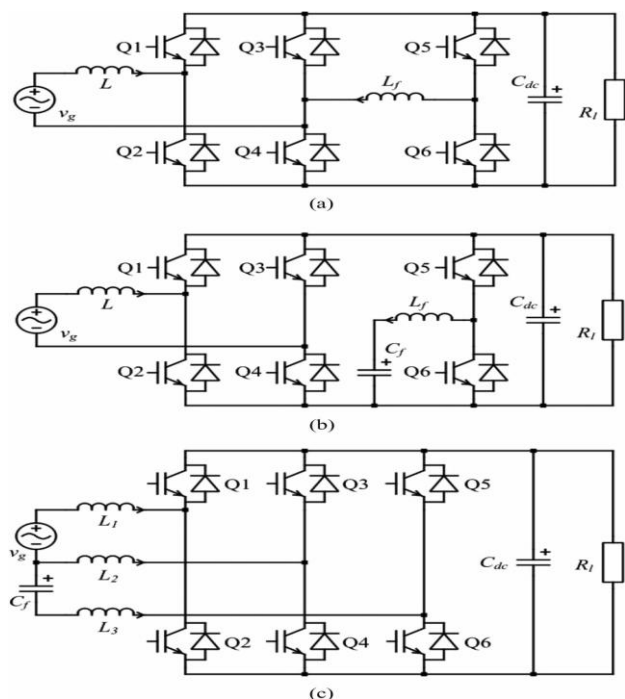

Fig.1. Active Power Decoupling Techniques

**LITERATURE REVIEW:**

**Sankala, A., Korhonen, J., Ström, J.P., Luukko, J., Silventoinen, P., Komulainen, R., Sarén, H., Södö, N., and Isaksson, D:**The MDC topology is introduced. Potential applications of the converter are presented, and its capability to change the voltage level is discussed. Simulation results are shown for a seven-level version of the converter operating in a 3.3 kV grid with an LR load. The first measurements of a three-level experimental system operating in a 400V grid and feeding a motor are reported. The author’s contribution: the principal author of the paper.

**Sankala, A., Korhonen, J., Ström, J.P., Luukko, J., Silventoinen, P., Komulainen, R., Sarén, H., Södö, N., and Isaksson, D:** The outline is similar to that of P1. The difference is in the thorough analysis of the medium frequency transformer link and more detailed measurement results of the experimental system. The power of the experimental system is increased by a factor of three compared with Publication P1, giving more insight into the dynamics of the converter topology.

**Korhonen, J., Sankala, A., Ström, J.P., Luukko J., Silventoinen, P., Komulainen, R., Sarén, H., Södö, N., and Isaksson, D., :** The publication discusses the four-quadrant operation and power flow control principles of the medium-frequency transformer link. Three principles are compared with each other: In the first principle only the primary-side bridges and in the second principle also the secondary-side bridges of the transformer are switched. The third principle uses

information from the load bridge controller and measurements to determine whether the corresponding transformer bridge should be switched or not. The third control principle is the preferred one according to the conclusions of the paper.

**Sankala, A., Korhonen, J., Ström, J.P., Silventoinen, P., Komulainen, R., Sarén, H., Södö, N., and Dilley, D.,** The application of series resonant circuits to improve the energy efficiency of the medium frequency transformer link is introduced. The asymmetry of the transformer link is found to have a significant effect on the performance of the series resonance. A compensating circuitry is suggested to overcome the asymmetry problem. The simulation results demonstrate the performance of the proposed method.

**Sankala, A., Korhonen, J., Purhonen, M., Ström, J.P., Silventoinen, P., Komulainen, R., Sarén, H., Södö, N., and Strandberg, S., :**The design and implementation of the control of the active front end of the converter are presented. The grid filter and AFE controller design are performed for an example 3.3 kV motor application. The performance of the example design is assessed with simulation results.

**Sankala, A., Korhonen, J., Hannonen, J., Ström, J.P., Silventoinen, P., Sarén, H., Komulainen, R., Strandberg, S., and Södö, N., :**An anti saturation control of the six-winding medium-frequency transformer is introduced. Additionally, the effects of the flux balance controller on the parallel windings on the primary and secondary side are discussed. A control algorithm that both controls the magnetic flux of the transformer and balances the loading of the parallel units is proposed. The algorithm has been granted a Finish patent in 2013.

**CONCLUSION:**

In this paper author is tried to review all available techniques related to Decoupling of Fluctuating Power Techniques in Single-Phase Systems through a Symmetrical Half-Bridge Circuit. Also author had reviewed the three different configurations of active power decoupling techniques. From the observation and papers cited it is observed that active power decoupling technique using three inductors is more suitable for prevention of power fluctuations in single phase circuit

**REFERENCES:**

- i. K. D. Gusseme, D. M. Van de Sype, A. P. M. Van den Bossche, and J. A. Melkebeek, “Input-current distortion of CCM boost PFC converters operated in DCM,” *IEEE Transactions on Industrial Electronics*, vol. 54, no. 2, pp. 858–865, 2007.

- ii. Jindong Zhang, Milan M. Jovanovit, and Fred C. Lee, "Comparison Between CCM Single- Stage And Two-Stage Boost PFC Converters," Applied power electronics conference and exposition (APEC), 14th Annual IEEE, 1999, pp. 335-341.
- iii. Jeong-Eon Park, Jong-Woo Kim, Byoung-Hee Lee and Gun-Woo Moon, "Design on Topologies for High Efficiency Two-Stage AC-DC Converter," Power Electronics and motion conference (IPEMC), 7th International IEEE, 2012, pp. 257-262.
- iv. Wonsuk Choi, Sungmo young, Dongkook Son, Seunghwan Shin and Dongseok Hyun, "Consideration to minimize power losses in Synchronous Rectification," 8th International Conference on Power Electronics - ECCE Asia, May 2011, The Shilla Jeju, Korea, IEEE 2011, pp. 2899-2905.
- v. Bob Bell and Eric Lee, Texas Instruments, Phoenix, Ariz., "How to power today: Boost converter finally get some respect !", Power design newsletter, June 2013.
- vi. S. Cuk, "Single-stage bridgeless isolated PFC converter achieves 98%efficiency," Power Electronics Technology Magazine, vol. 39, pp. 22-31, October 2010.
- vii. S. Norrga, "Experimental study of a soft-switched isolated bidirectional AC-DC converter without auxiliary circuit," IEEE Transactions on Power Electronics, vol. 21, no. 6, pp. 1580-1587, 2006.
- viii. M. H. Kheraluwala and R. W. De Doncker, "Single phase unity power factor control for dual active bridge converter," in Proc. IEEE Industry Applications Society Annual Meeting, 1993, pp. 909-916.
- ix. J. Everts, J. Van den Keybus, and J. Driesen, "Switching control strategy to extend the ZVS operating range of a dual active bridge AC-DC converter," in Proc. IEEE Energy Conversion Congress and Exposition (ECCE), 2011, pp. 4107-4114.
- x. Daolian Chen and Jian Liu, "The Uni-Polarity Phase-Shifted Controlled Voltage Mode ac-ac Converters with High Frequency AC Link," IEEE Transactions on Power Electronics, vol. 21, no. 4, pp. 889 -905, July 2006.
- xi. F. Jauch, and J. Biela, "Single-Phase Single-Stage Bidirectional Isolated ZVS ac-dc Converter with PFC," 15th International Power Electronics and Motion Control Conference, EPE-PEMC 2012 ECCE Europe, Novi Sad, Serbia.
- xii. Ganesh Arun, Wajihah Shireen and Prasad N. Enjeti, "Improved active power-factor correction Circuit using a zero-voltage-switching boost converter," IEEE Transactions On Power Electronics, Vol. 13, No. 2, pp. 308 - 314, March 1998.
- xiii. Jordi Everts z, Jeroen Van den Keybus, Florian Krismer z, Johan Driesen, and Johann W. Kolarz, "Switching Control Strategy for Full ZVS Soft-Switching Operation of a Dual Active Bridge ac - dc Converter, " Dept. of Electrical Engineering ESAT-ELECTA Katholieke Universiteit Leuven, Belgium and Power Electronic Systems (PES) Laboratory ETH Zurich, Switzerland, pp. 1048 - 1055, 2012.
- xiv. Bin Su and Zhengyu Lu, Senior Member, IEEE, "An Interleaved Totem-Pole Boost Bridgeless Rectifier with Reduced Reverse-Recovery Problems for Power Factor Correction," IEEE transactions on power electronics, vol. 25, no. 6, pp. 1406 - 1415, June 2010
- xv. Mihail Hr. Antchev, Mariya P. Petkova and Vanjo T. Gurgulitsov, Hristo M. Antchev, "study of single-phase bidirectional ac - dc converter with a high power factor," IEEE, pp. 1521 - 1527, 2009.
- xvi. Yusuke Hahashi and Masato Mino, "High-density Bidirectional Rectifier for Next Generation 380-V DC Distribution System" Applied Power Electronics Conference and Exposition (APEC), 27th Annual IEEE conference, pp. 2455-2460, 2012.
- xvii. Y.-F. Wu, R. Coffie, N. Fichtenbaum, Y. Dora, C.S. Suh, L. Shen, P. Parikh and U.K. Mishra, "Total GaN Solution to Electrical Power Conversion," Device research conference(DRC), 69th Annual, pp. 217 - 218, 2011.
- xviii. F. Gao, D. Li, P. C. Loh, Y. Tang, and P. Wang, "Indirect dc-link voltage control of two-stage single-phase PV inverter," in Proc. IEEE Appl. Power Electron. Conf., Sep. 2009, pp. 1166-1172.
- xix. A. Lesnicar and R. Marquardt, "An innovative modular multilevel converter topology suitable for a wide power range," in Proc. IEEE PowerTech Conf., Bologna, Italy, 2003, pp. 1-6.
- xx. Yifeng Wu, Matt Jacob-Mitos, Marcia L. Moore, And Sten Heikman, "A 97.8% efficient GaN HEMT boost converter with 300-W output power at 1 MHz," IEEE Electron Device Letters, Vol. 29, No. 8, August 2008, pp. 824 - 826.
- xxi. Srabanti Chowdhury, Brian L Swenson, Man Hoi Wong and Umesh K Mishra4, "Current status and scope of Gallium Nitride-based vertical transistors for high-power electronics application," IOP science, pp. 1 - 9, 2014.
- xxii. Konstantin P. Louganski and Jih-Sheng Lai, "Active Compensation of the Input Filter Capacitor Current in Single-Phase PFC Boost Converters, " IEEE COMPEL Workshop, Rensselaer Polytechnic Institute, Troy, NY, USA, pp. 282 - 288, July 16-19, 2006.
- xxiii. H. Li, K. Zhang, H. Zhao, S. Fan, and J. Xiong, "Active power decoupling for high-power single-phase

- 
- PWM rectifiers," *IEEE Trans. Power Electron.*, vol. 28, no. 3, pp. 1308–1319, Mar. 2013.
- xxiv. S. V. Araujo, P. Zacharias, and R. Mallwitz, "Highly efficient single-phase transformerless inverters for grid-connected photovoltaic systems," *IEEE Trans. Ind. Electron.*, vol. 57, no. 9, pp. 3118–3128, Sep. 2010.
- xxv. M. Chen, K. K. Afridi, and D. J. Perreault, "Stacked switched capacitor energy buffer architecture," *IEEE Trans. Power Electron.*, vol. 28, no. 11, pp. 5183–5195, Nov. 2013.
- xxvi. H. Wang, H. S. H. Chung, and W. Liu, "Use of a series voltage compensator for reduction of the DC-Link capacitance in a Capacitor supported system," *IEEE Trans. Power Electron.*, vol. 29, no. 3, pp. 1163– 1175, Mar. 2014.

ICITER-2016