

A REVIEW ON LEAF RECOGNITION

Pradip Wable

Department of Electronics and Telecommunication, SKNCOE, Pune, India
pwable91@gmail.com

Purushottam Chilveri

Department of Electronics and Telecommunication, SKNCOE, Pune, India
pgchilveri@gmail.com

ABSTRACT

Plant is closely related to humans. How to quickly recognize an unknown plant without related professional knowledge is a huge challenge. With the development of image processing and pattern recognition, it is possible to recognize leaf image quickly from which species it belongs to. This paper gives review of leaf recognition and methods to improve recognition rate. Different databases used to evaluate the performance of various methods. Various features are extracted in order to improve recognition rate, such as entropy sequence, Hu's invariants, Zernike moments, form factor, circularity, rectangularity, aspect ratio, Ring projection wavelet fractal feature.

KEYWORDS— Feature extraction, image processing, classification.

I. INTRODUCTION

Leaf recognition is generally based on the observation of the morphological characteristics of leaf, but it will be a tricky task for experienced botanists to identify the plants because of the large number of species existing in the world. In this case, it is helpful and significant for developing a quick and efficient plant recognition system based on computer to identify the plant species. With the development of image processing and pattern recognition, it is available to apply them to recognize plant automatically. Many studies in the past decades have shown that leaf contains rich information (e.g. color, shape, texture) for recognition. The shape of leaf is the general feature for classification, while the texture of leaf is becoming another important feature. As the color of a leaf may vary with the climatic and seasons conditions, and most plants have similar color (e.g. green), so color is not commonly used in classification. Most of the existing methods generally employ the shape feature.

II. BLOCK DIAGRAM AND DESCRIPTION

Figure 1 shows block diagram of leaf recognition. Block diagram consist of following blocks.

A. INPUT LEAF IMAGE ACQUIREMENT

Leaf image can be obtained by flatbed optical scanner. Now a day's many leaf Image databases are built by using scanner. First, the leaf should have complete contour in the image if the leaf has some damaged places, the size of the damaged place should be small enough. Only this way, it cannot affect the recognition result. Three different datasets are employed to test the performance of every algorithm.

B. LEAF IMAGE PREPROCESSING

Usually, the acquired leaf image is the color image with single background. In this step, there are geometric transformation and petiole removal. The aim of geometric transformation is to make leaf in the center of image, where petiole lies in the bottom and leaf apex lies in the top. Then petiole is deleted in order to avoid the bad influence on the result of recognition. Different kinds of leaves have different width of petiole, even for the same kind of leaves their width also varies according to the different environment. Because the blade is wider than the petiole, the petiole could be deleted by morphological image processing.

C. FEATURE EXTRACTION

Texture feature can be described by Entropy sequence, Zernike moments and Hu's invariants. Shape feature is described by aspect ratio, rectangularity, form factor and circularity. All feature parameters are explained in detail as following:

1. ENTROPY SEQUENCE

For the PCNN, the neurons associated with each group of spatially connected pixels with similar intensities tend to pulse together. It is a powerful characteristic for feature extraction. PCNN works in the form of iteration process. When an image is imported into PCNN, after the n th iteration, PCNN will export a binary image $y[n]$. These output images contain more feature information of input image. But these images have too many data to be taken as feature parameters directly. It is good way to reduce data dimension. Usually, two commonly used methods are time signature and entropy sequence [1]. Figure 2 shows pulse coupled neuron.

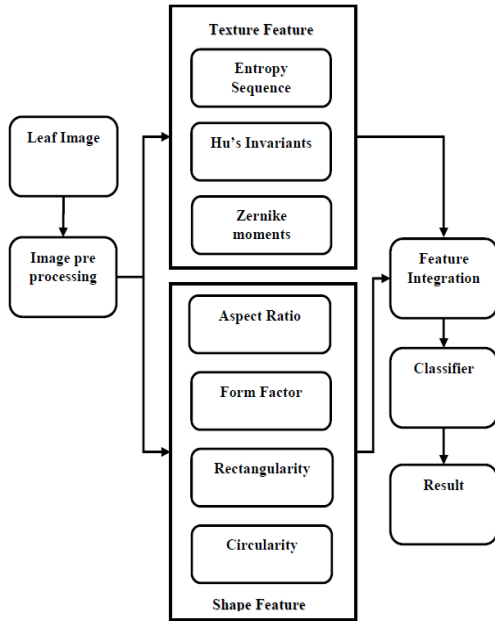

Figure 1: Block Diagram of Leaf Recognition System

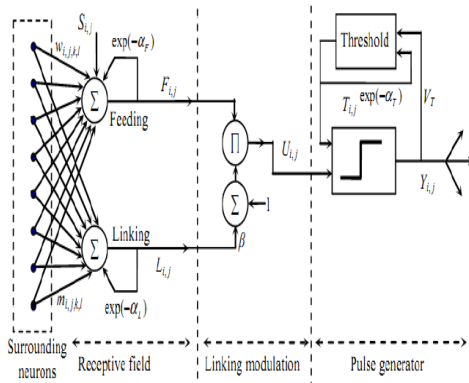

Figure 2: Pulse Coupled Neuron Structure

Johnson proposes the creation of time signature (also called image signature, time signal or time series) with the PCNN [3]. The time signature $G[n]$ can be computed by the following equation

$$G[n] = \sum_{i,j} Y_{ij}[n] \quad (1)$$

The entropy sequence $E_n[n]$ is defined by the following expression.

$$E_n[n] = -P_0[n] \log_2 P_0[n] - P_1[n] \log_2 P_1[n] \quad (2)$$

Where, $P_0[n]$ and $P_1[n]$ represent probability when $Y_{ij}[n] = 0$ and $Y_{ij}[n] = 1$ in the output $Y[n]$. Both two methods implement dimension reduction from 2D data to 1D data, and entropy sequence and time signature have the similar invariant characteristic of simple transformation (e.g., rotation, scaling and translation) [4]. Entropy sequence is better than time signature for plant recognition.

2. ZERNIKE MOMENTS

Zernike moments are a type of moment function, which are the projections of an image onto a set of complex Zernike polynomials. Zernike moments can represent the features of an image with no redundancy or overlap of information between the moments, because Zernike polynomials are orthogonal. Due to these characteristics, Zernike moments as feature sets have been applied in pattern recognition.

3. HU'S INVARIANTS

Hu derived relative and absolute combinations of moments that are invariant with respect to scale, position and orientation. He defined seven functions, computed from central moments of orders two and three, which were invariant with respect to object scale, translation and rotation

4. ASPECT RATIO

Aspect ratio denotes the ratio of length to width of the external rectangle of leaf contour.

5. RECTANGULARITY

Rectangularity is defined by

$$R = \frac{S_L}{S_E} \quad (3)$$

Where, S_L and S_E represents the area of the external rectangle of leaf [1].

6. FORM FACTOR

Form factor is used to describe the difference between the contour of leaf and the circle. It is defined as

$$F = \frac{4\pi S_L}{P_L^2} \quad (4)$$

Where, S_L is area of the leaf and P_L is the total length of leaf contour [1].

7. CIRCULARITY

Circularity (C) is defined by as

$$c = \frac{\mu_d}{\sigma_d} \quad (5)$$

$$\mu_d = \frac{1}{N} \sum_{N=0}^{N-1} \|(X_i, Y_j) - (\bar{X}, \bar{Y})\|$$

$$\sigma_d = \frac{1}{N} \sum_{N=0}^{N-1} (\|(X_i, Y_j) - (\bar{X}, \bar{Y})\| - \mu_d)^2$$

Where, μ is the average distance from the leaf contour to the centroid of leaf. σ is the standard deviation of the distance from the leaf contour to the centroid of leaf N is pixel number [1].

8. RING PROJECTION WAVELET FRACTAL FEATURE

Ring Projection Wavelet Fractal (RPWFF) is a feature used for description of leaf image. This method reduces dimensionality i.e 2D to 1D [6].

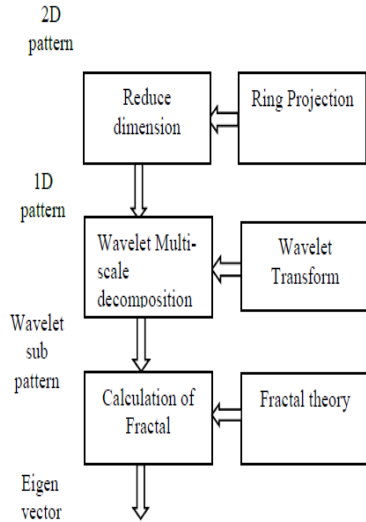

Figure 3: Ring Projection Wavelet Fractal (RPWFF) flowchart

Figure 3 shows flowchart of Ring Projection Wavelet Fractal (RPWFF). Leaf venation feature is extracted using edge detector. Two dimensional pattern is represented by preprocessed binary image, grayscale image after binarization is represented as

$$p(x, y) = \begin{cases} 1, & \text{if } x, y \in I \\ 0, & \text{otherwise} \end{cases}$$

Where I corresponds to white area of leaf image. In figure 4 $p(x, y)$ is multivalued function regarded as 2D density function distributing in the plane [6]. Density function is uniform distributed, upon which we can get barycentric coordinates $m_0(x_0, y_0)$. Then we move the coordinate center to the point m_0 .

$$\text{Let } M = \frac{\max_{n \in I} |N(x, y) - m_0(x_0, y_0)|}{n} \quad (6)$$

Where $|N(x, y) - m_0(x_0, y_0)|$ is the distance between two points on plane, N and m_0 . The original Cartesian coordinates can be transformed into polar coordinates as $x = r \cos \theta$, $y = r \sin \theta$. $p(x, y) = p(r \cos \theta, r \sin \theta)$

(7)

Where $r \in [0, \infty]$, $\theta \in [0, 2\pi]$

For any point $r \in [0, M]$, we can calculate the following integral $f(r) = \int_0^{2\pi} p(r \cos \theta, r \sin \theta) d\theta$

(18)

Where $f(r)$ can be regarded as a series of concentric circles in the circle distribution. As shown in figure 4 the 1D pattern is rotation-invariant because barcentric has the characteristic of rotation-invariance and projection is carried out within concentric circles.

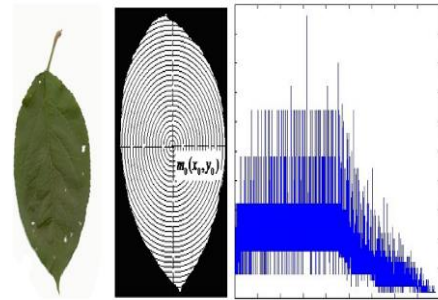

Figure 4: Two-dimensional images converted into one-dimensional signal [6].

D. FEATURE INTEGRATION

Feature parameters are integrated into a single matrix, after that this matrix of features used for classifier training.

E. CLASSIFICATION

Classification is the final step of plant recognition. Various classifiers used for classification of leaf image such as probabilistic neural network, support vector machine and K-nearest neighbor.

F. RESULT

Performance analysis of Leaf recognition is shown in Table 1. the recognition rate (R) is a commonly used and efficient evaluation method, which is defined as follow

$$R = \frac{N_{\text{Right}}}{N_{\text{Total}}} \times 100\% \quad (8)$$

Here, N_{Total} is the total number of the testing samples (not contain the training sample) and N_{Right} is the number of samples that are recognized correctly [1].

Table 1 Performance analysis of Leaf Recognition

Study Group	Year	Method	Classifier	Database	Recognition rate %
Stephen Gang et al[5]	2007	PNN	PNN	FLAVIA	73.52
				MEW2012	36.07
				ICL	41.81
Qing-Ping Wang et al[6]	2013	RPWFF	K-NN	FLAVIA	51.3
				MEW2012	25.04
				ICL	18.25
Zhao bin Wang et al[1]	2015	PCNN	SVM	FLAVIA	96.67
				MEW2012	91.2
				ICL	91.56

III. CONCLUSION

Three different datasets are employed to test the performance of every algorithms in table I, various features are extracted in order to improve recognition rate, in every method recognition rate is higher for FLAVIA database, and hence FLAVIA database is suitable for analysis of algorithm. Recognition rate obtained by PCNN (Pulse Coupled Neural Network) method is higher than other two methods.

REFERENCES

- [1] Zhaobin Wang, Xiaoguang Sun, Yaonan Zhang, Zhu Ying, Yide Ma, " Leaf recognition based on PCNN ", Neural Computation and applications, Springer, March 2015.
- [2] Ming-kuei , Hu, "Visual Pattern Recognition by Moment Invariants", IRE TRANSACTIONS ON INFORMATION THEORY,pp.. 179-187.
- [3] H. J. Reitboeck, M. Arndt, P. Dicke, "Feature Linking via Synchronization among Distributed Assemblies: Simulations of Results from Cat Visual Cortex", Neural Computation 2, 293-307 (1990).
- [4] Zhaobin Wang, Yide Ma, Feiyan Cheng, Lizhen Yang, "Review of pulse-coupled neural networks", Image and Vision Computing 28 (2010) 5–13.
- [5] Wu SG, "A leaf recognition algorithm for plant classification using Probabilistic Neural Network",IEEE international symposium on signal processing and information technology, vol 1–3, pp 120–125,2007.
- [6] Ji-xiang Du n ,Chuan-Min Zhai, Qing-Ping Wang," Recognition of plant leaf image based on fractal dimension features"Neurocomputing 116 (2013) 150 – 156.