

Paper ID: E&TC23

A LOW COST PORTABLE REFRESHABLE PAPERLESS BRAILLE FOR BLIND PEOPLE

Ashwini S. Bagane,

Dept. of Electronics & Telecommunication Engg., RIT, Islampur, India.

Prof. S.R. Jagtap

Dept. of Electronics & Telecommunication Engg., RIT, Islampur, India.

Abstract- Visually impaired people are the indispensable unit of our community. Their disabilities about the eyesight make them less accessible to computer, educational software and digital data which turn to limit their own knowledge. The main problem faced by them is to read digital data in terms of Braille language. Braille language is represented by 6 dots arranged in 3x2 matrix and it is readable only through the sense of touch. This paper introduces electronic Braille which consists of Braille reader and Braille writer. Reading is possible through tactile pin module arranged in 3x2 matrix and writing is possible through the Braille keypad. Whatever data is to be read or write will be stored in the SD card. This small electronic Braille device will be portable and has a low cost than that of learning materials of blind people.

Index Terms— ATMEGA 2560, Braille cell, Braille keypad, tactile pin module, visually impaired people.

I. INTRODUCTION

According to the statistical analysis of the visually impaired peoples by the World Health Organization, among 285 million peoples 246 million have low vision whereas 39 million are totally blind. This analysis shows that the visually impaired peoples cannot be ignored [1]. The visually impaired as well as the deaf and blind people are facing distinct unpleasant problem for communication with outer world, because vision is the most important sense to acquire maximum information and knowledge. But to live along with this blindness, a visually impaired people forces to build a strong capability to make constructive use of sense of touch. To read information the blind people uses the sense of touch and the sense of touch can be used to develop dot patterns called as Braille. Braille delicate tactile formation. This perception for the sense of touch makes visually handicapped people intuitive end users of technologies that aim to exchange information through this secondary sense i.e. sense of touch[2]. Braille or tactile writing and reading had found by the Louis Braille, was born in France in 1809. He innovated tactile writing and reading system by 1820, but had not welcomed preferably as a writing and reading channel for visually impaired. It was accepted as a standardized tactile reading and writing for the visually

handicapped in 1918 [3]. Reading, writing as well as understanding of outer world knowledge for the blind people is performed via Braille only. According to the international standard of cell, one Braille cell is consisting of 6 dots arranged in matrix as shown in fig. 1. Braille is written through 63 different number of combination produced over one Braille cell. For the given English alphabet, the specific dot(s) of the Braille cell rose than others. Blind person uses sense of touch to read the Braille cell and then understands the given English alphabet.

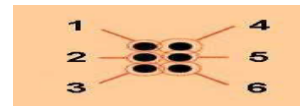

Fig. 1 - Six dot Braille cell

According to International building standard for a Braille cell (as shown in fig. 2), tactile pins should be raised up to 0.5 mm, distance between centers of the two dots is 2.5mm and diameter of one dot should be 1 mm [1].

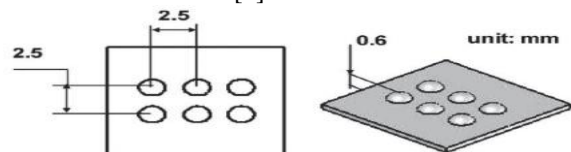

Fig. 2 - International building standard for a Braille cell

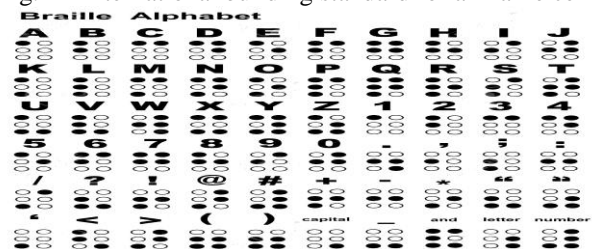
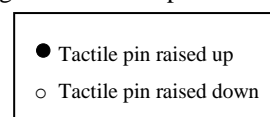

Fig. 3 - Braille Alphabet Chart



The fig. 3 shows equivalent Braille alphabet for English alphabet. For the English alphabet a to i and j as well as digit 1 to 9 and 0 have the same tactile pin combination but to

Paper ID: E&TC23

identify the numbers, the dots 3,4,5,6 raised first and then numbers are represented [3].

Braille is categorized under 2 grades of representation that is the Grade 1 Braille and the Grade 2 Braille. Grade 1 Braille is also called as un-contracted type of Braille in which each alphabet or numerical digit is represented by one Braille cell [4].

e.g. Braille word



To write "Braille word", it requires 13 Braille cells including space as shown above.

Grade 2 Braille is also called as contracted Braille in which group of alphabet is assigned to one or two Braille cell.

e. g. braille word



To write "braille word", it requires 6 Braille cells including space as show above. In most cases Grade 2 Braille is preferably used, because it requires less space.

Section II describes earlier work of the previous research. Section III describes detailed proposed methodology for Braille to text conversion or vice versa. Section IV describes system architecture of the proposed model for Braille to text conversion and text to Braille conversion. Section V describes the simulation results of Braille keypad obtained by showing the snapshot. Section VI describes the conclusion of the overall work and section VII describes references.

II. EARLIER WORK

Individualize researches have been studied on the Braille to text and text to Braille conversion using the different methodologies.

Dwijen Rudrapal, Ruman Sarkar, Smita Das introduced a new communication technique which is the medium for the visually impaired and deaf blind people. It consists of three different sub systems which provide different potential to develop & to reduce denial barrier between the deaf blind and visually impaired people. The system consists of three modules: i) Body-Braille system which is low cost and portable for displaying Braille characters using six micro vibrators, ii) Braille writer for writing the Braille, iii) A remote communication system through SMS facility[1].

Gareth Evans, Paul Blenkhorn implemented the system which describes a novel method for automatic generation of Braille documents from Microsoft word documents, by using the Word Object Model (WOM). The translation system can map the layout format in the printed document into suitable Braille equivalent [2].

Vrushabh S. Dharme, S. P. Karmore described a model which minimizes error rate, improves ease of reading of Braille with

fast conversion rate. He invented the Automated Comparison Algorithm (ACA) which works on text to Braille conversion. The generated equivalent Braille pattern is transferred to the Braille board according to standard Braille text. The Braille pattern generation is mainly based on the text matching and comparison technique. The proposed system also has conversion speed control future for speeding up or slowing down the speed of conversion according to the grasp capability and need of blind reader [3].

Alejandro R. Garcia Ramirez, Luiz Gustavo, Marcelo Bernart Schmidt introduced a single Braille cell system with voice recognition model. Single Braille cell was designed into 2 modules: a) training module and b) reading module. The single Braille cell was designed by using 6 servos which are triggered using microcontroller. Computer driver commands are used to control the position of the servos through UART serial protocol system [4].

Abhinav Kulkarni, Kishor Bhurchandi described electronic-book reading device for visually impaired people which consist of 3x2 matrix pair of tactile pin module called as a refreshable Braille display unit. Referred device uses innovative technique of two tactile refreshable Braille cells. Braille cell is made up by using 6 solenoid pins arranged in 3x2 matrix. Text is alternatively printed on two Braille cell. Speed of printing is two characters per second. The system also uses SD card for file storage [5].

K. R. Subramanian, N. Sriskan than described a model named as a Braille Display Terminal (BDT) which empowers visually disabled people to do the real time interaction with the computer hardware. The commercially recent products consist of Braille printout as well as voice copy of Braille and have certain limitations related to the interaction and access speed. The Braille Display Terminal (BDT) described a monitor for visually impaired people also designing of hardware and software tools are also presented in this paper [6].

Reading, writing and understanding of outer world knowledge is performed via Braille only. To develop Braille for blind people embosser, a specially designed impact printer and white paper are used habitually for Braille printing literature in Braille. But cost of specially designed white paper and Braille embosser is considerably too high, which causes to restrict its access only to the financially elite class. It should consider that 90% of the total impaired people live in middle and low income economies. Thus attempts are being made to make transition from Braille books to refreshable Braille display, which are portable, refreshable and personalized. Current products of Braille are too expensive and also have limited access; especially they are not economically reasonable for developing countries [1]. Hence there is a huge scope in this application for development of portable and low-cost solution.

Paper ID: E&TC23

Document describes electronic Braille for visually impaired a person that is readable as well as writable also. A blind person has access to learn using Braille script, which consists of an alphabet represented by combination of six dots. Also Braille writing will be possible through small Braille keyboard to convert Braille character into alphanumeric character. SD card is used for two purposes, first is store the typed data via keyboard in the .txt form and second is to read the data from files and folders stored in SD card via tactile pin module. To make the system more user friendly, piezo electric buzzer is used for detection of SD-CARD, resume or pause and scroll button press.

III. METHODOLOGY

The proposed dissertation work intends to design low cost, portable, refreshable paperless Braille for visually impaired people. It includes Braille keypad to write the Braille and Braille reader which consist of 1 or two Braille cell to read the Braille.

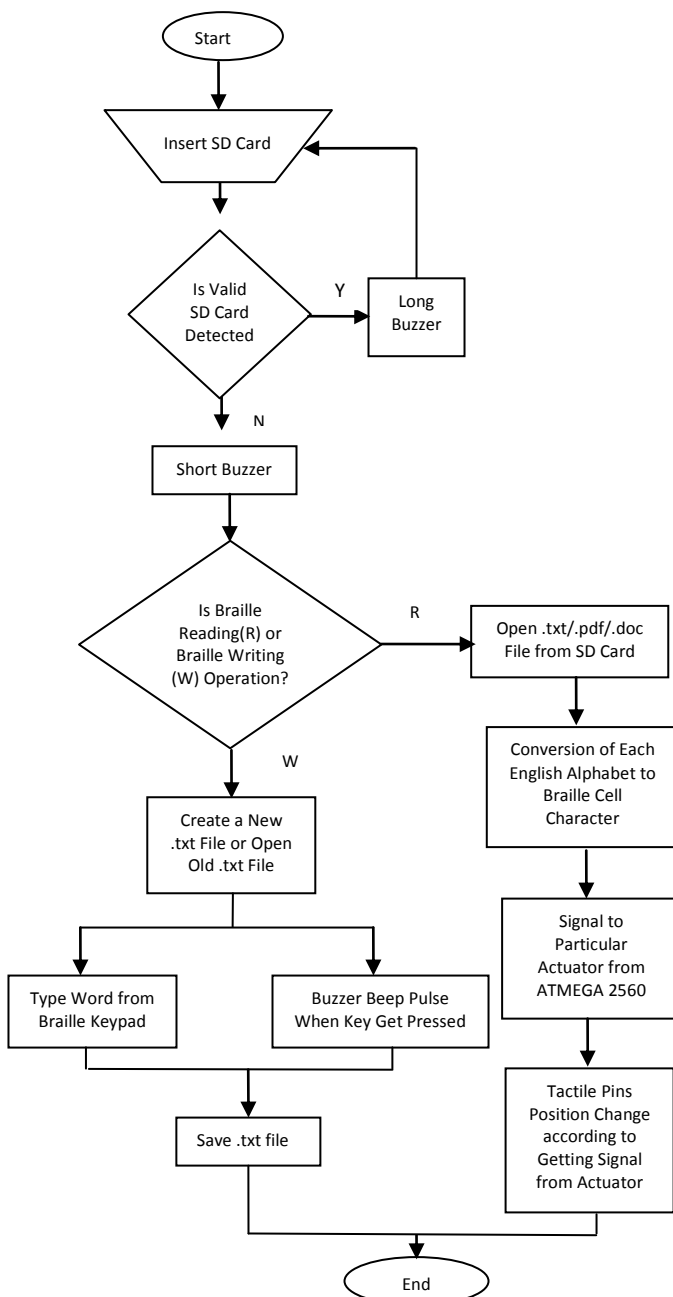

Fig. 4 – Flowchart

The typed Braille data is saved in SD card and whatever English data (i.e. .txt, .pdf and .doc files) saved in the SD card should be fetching to tactile pin module. As described earlier for given English alphabet particular tactile pin or solenoid pin will be rose upward or downward. Fig. 4 shows proposed methodology. As shown in fig. 4 user should insert SD card. System will detect valid SD card has inserted or not. Buzzer is used for audio notifications to detect SD card is properly inserted or not. Short or long buzzer beep will be produced to give the notifications. User should select reading or writing operation. If writing operation has selected existed file will be opened or new file will be created. After opening the file blind person will type the data from Braille keypad. On each key press, buzzer will beep to identify key is pressed or not. Edited .txt file will be saved automatically in the SD card. If reading operation has selected, system will open .txt, .pdf or .doc file from SD card. Microcontroller will convert each English alphabet to Braille cell character. It will give a logic 1 signal to particular actuator from a set of actuators which are connected to tactile pin module. 6 actuators are required for 1 Braille cell. Tactile pin module is nothing but set of 1 or 2 Braille cells. Particular tactile pin will change its position to upward or downward according to logic 1 signal given to the actuator.

ATMEGA 2560 microcontroller is selected since proposed system requires more number of ports. Arduino 1.6.7 software is used for programming. Programming is done in C++ language. Proteus 7.8 is used for simulation.

IV. SYSTEM ARCHITECTURE

The proposed dissertation work intends to design a low cost, portable, refreshable paperless Braille for visually impaired people. The proposed device has following characteristics.

1. Reading of English alphabetical, numerical data in terms of Braille
2. Writing the Braille through digital Braille writer.
3. Securing the data by using SD card
4. Reading .txt, .doc and .pdf file

A. Working principle of the system

As shown in fig. 5, controller is supplied through rechargeable battery or adapter. Key board is used to write the Braille data. It is nothing but a simple digital Braille writer which consists of control keypad and Braille keypad. There are 17 keys on the key board, out of that only 11 keys are used in Braille keypad to generate Braille code pattern for any alphabet, number and special symbol. Rest of the keys is used in control keypad for control and navigation operations like spacing, file or folder scrolling. If user want to store the read page or want to refresh the display, interrupt keys are used from control keypad. It will give an interrupt signal to controller according to user requirement. Files like .pdf, .txt, .doc files which has

Paper ID: E&TC23

een downloaded through internet are also readable to blind people. These files are readable from tactile pin module. Tactile pin module is the Braille output through which blind people can understand the information through raised tactile pins. Each alphabet from the stored files are converted to Braille alphabet and then displayed on tactile pin module. The position of tactile pins to rise upward or downward is decided by actuators itself. Actuator is used to actuate the tactile pin.

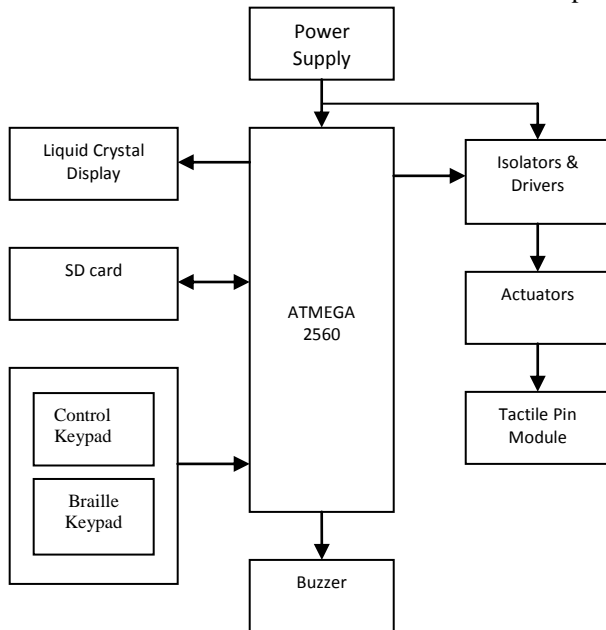

Fig. 5-Block Diagram

To drive the actuator, driver circuit is used. The Driver will decide which actuator to be actuated. Isolator is used to separate ground of control section and power section. Figure 3 shows how the Braille is written i.e. if user want to write an English letter A, a logic one signal is given to the first pin (as shown in fig. 3) and so on.

To make the system more user friendly, piezo electric buzzer will be used for audio notification. Buzzer will be beep at events like SD card detection and key pressing from Braille keypad or control keypad.

The software part of the proposed system composed of arduino mega C Compiler of version arduino 1.6.7.windows. Programming language is C++. Proteus 7.8 have used for showing the simulation.

V. RESULT

Fig. 6 shows simulation result of Braille keypad. As shown in fig. 6, there are 10 keys are used to write in Braille language. From set of 6 keys, up to 68 different combinations has generated. Set of 4 keys are used to select numeral value. For example if these 4 keys will be pressed and first key from group of 6 keys will be pressed then “1” will be displayed on 16x2 LCD. This typed “1” will be stored in the

SD card also. From set of two keys, first key is used for capital letter selection. For example if this key will be pressed and first key from group of 6 keys will be pressed then “A” will be displayed on 16x2 LCD, otherwise “a” will be displayed on LCD. 16x2 LCD shows typed words and special symbols. Again this typed data will be stored in .txt form in the SD card. Second key from set of 2 keys is used for spacing. After pressing of this key it will create blank space between 2 words. 16x2 LCD is used for non blind person to see what data has typed from Braille keypad. Buzzer beeps on events like SD card detection and key pressing. Since some ports of arduino ATMEGA 2560 has not internal pull up. Hence external pull up is connected to each key as shown in fig. 6.

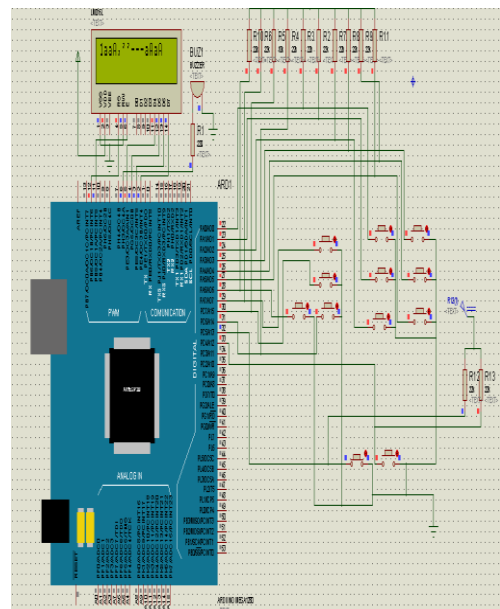

Fig. 6-Simulation diagram on proteus 7.8

VI. CONCLUSION

There are two types of Braille language, Grade 1 Braille and Grade 2 Braille. In Grade 1 Braille each English alphabet is represented by one Braille cell and in Grade 2 Braille group of alphabets are represented by one or two Braille cells. Designed Braille keypad is used to write the word in the form of Braille. This typed Braille data is stored in the SD card. Tactile pin module is used to read the Braille data. Audio notifications are used to indicate proper insertion of SD card, valid SD card detection, valid files and folders available on SD card and valid key pressing etc. ATMEGA 2560 converts Braille language to English alphabet or vice versa using arduino 1.6.7 software. Simulation is done on proteus 7.8.

VII. REFERENCES

[1]Dwijen Rudrapal, Ruman Sarkar, Smitta Das, “A Low Cost Micro electromechanical Braille for blind people to communicate with blind or deaf blind people through SMS

Paper ID: E&TC23

- subsystem”, 3rd International Conference of the Advance Computing Conference(IACC),pp. 1529-1532, 2013.
- [2]Gareth Evans, Paul Blenkhorn, “Automated Braille Production from Word-Processed Documents”, IEEE Transactions on Neural Systems and Rehabilitation Engineering, Vol. 9, No. 1, pp 81-85, March 2001.
- [3]Vrushabh S. Dharme, S. P. Karmore, “A Electro-Micromechanically Actuated Text to Braille Converted Refreshable Display with the Mono Cell”, International Journal of Science and Research (IJSR), Vol. 4, No. 5 pp. 143-147, May 2015
- [4]Alejandro R. Garcia Ramirez, Luiz Gustavo, Marcelo Bernart Schmidt, “Single Braille Cell”, 5th ISSNIP-IEEE international conference on Bio signals and Bio robotics, 26-28/May/2014.
- [5]Abhinav Kulkarni, Kishor Bhurchandi, “Low cost e-book reading device for blind people”, 2015 International Conference on Computing Communication Control and Automation, pp. 516-521.
- [6]K. R. Subramanian, N. Sriskanthan, “Braille Display Terminal For Personal Computers”, IEEE Transactions on Consumer Electronics, Vol. 36, No. 2, pp. 121-128, May 1990.
- [7] www.euroblind.org